

5					4					3					2					1									
D																													
C																													
B																													
A																													
															A														
															Title														
															<Title>														
Size					Document Number										Rev														
A					<Doc>										<Rev Code>														
Date:															Friday, November 18, 2022					Sheet					1 of 1				
5					4					3					2					1									

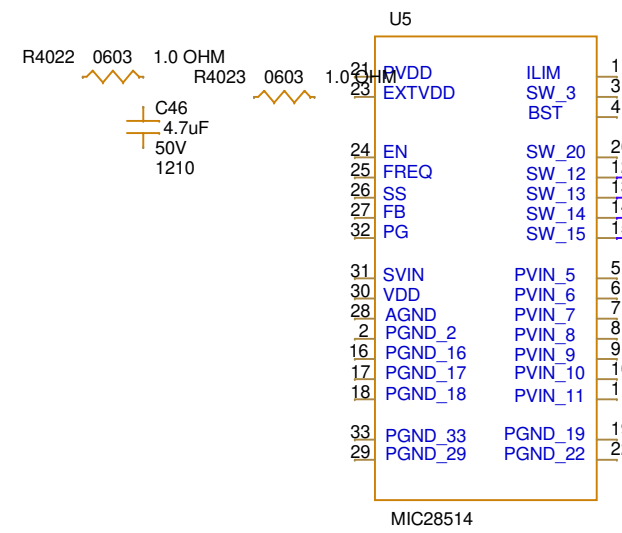

Title		
<Title>		
Size	Document Number	Rev
B	<Doc>	<Rev Co
Date:	Tuesday, November 29, 2022	Sheet 1 of 1

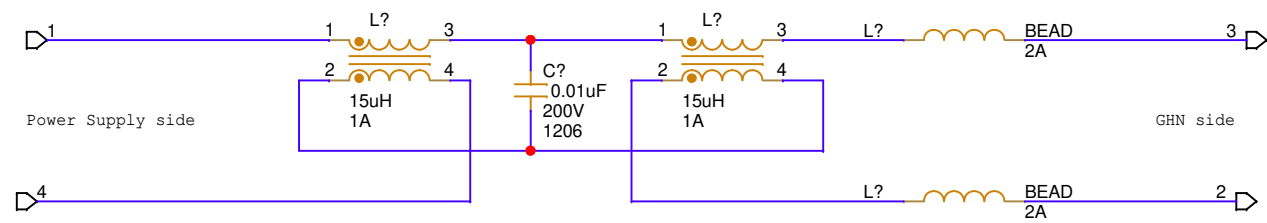

Title		
<Title>		
Size	Document Number	Rev
B	<Doc>	<Rev Co
Date:	Tuesday, November 29, 2022	Sheet 1 of 1

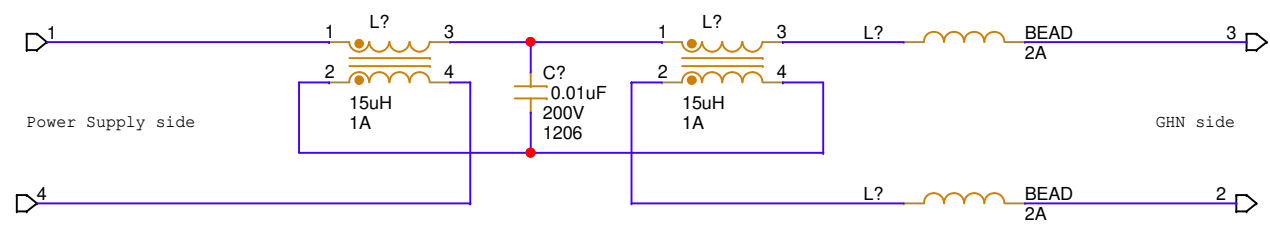

Title		
<Title>		
Size	Document Number	Rev
B	<Doc>	<Rev Co
Date:	Tuesday, November 29, 2022	Sheet 1 of 1

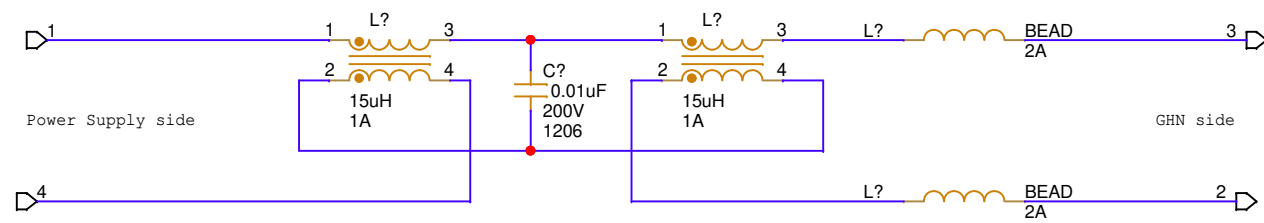

Title		
<Title>		
Size	Document Number	Rev
B	<Doc>	<Rev Co
Date:	Tuesday, November 29, 2022	Sheet 1 of 1

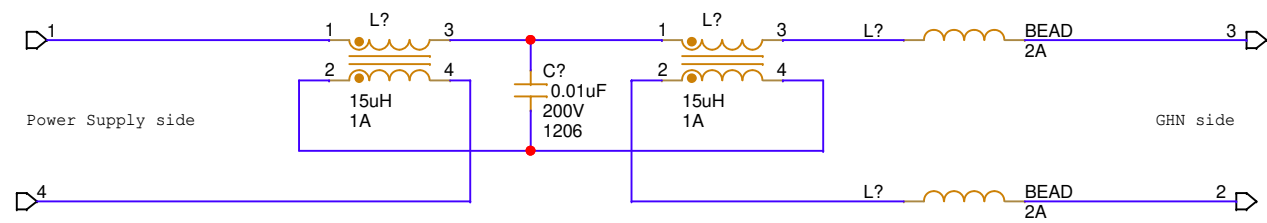

Title		
<Title>		
Size	Document Number	Rev
B	<Doc>	<Rev Co
Date:	Tuesday, November 29, 2022	Sheet 1 of 1

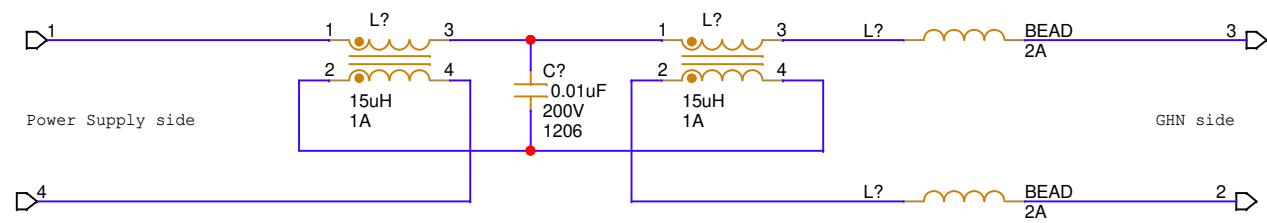

Title		
<Title>		
Size	Document Number	Rev
B	<Doc>	<Rev Co
Date:	Tuesday, November 29, 2022	Sheet 1 of 1

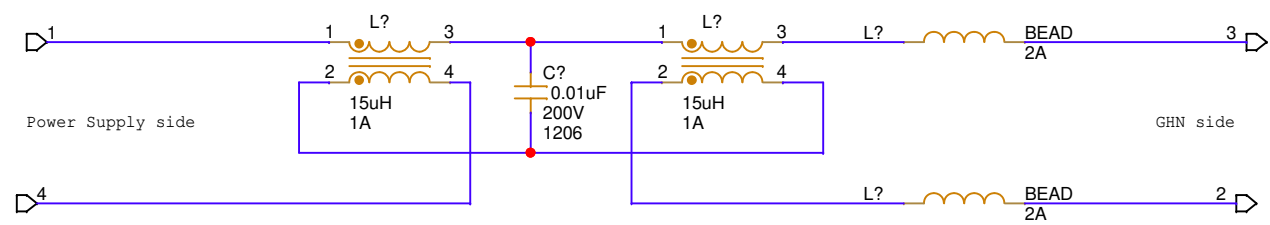

Title		
<Title>		
Size	Document Number	Rev
B	<Doc>	<Rev Co
Date:	Tuesday, November 29, 2022	Sheet 1 of 1



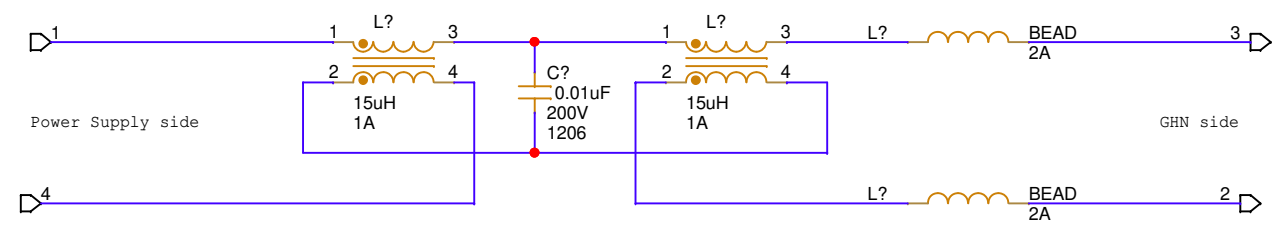

Title		
<Title>		
Size	Document Number	Rev
B	<Doc>	<Rev Co
Date:	Tuesday, November 29, 2022	Sheet 1 of 1

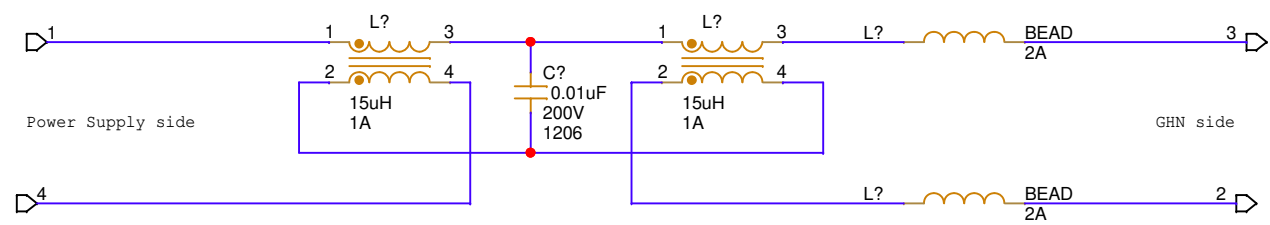

Title		
<Title>		
Size	Document Number	Rev
B	<Doc>	<Rev Co
Date:	Tuesday, November 29, 2022	Sheet 1 of 1

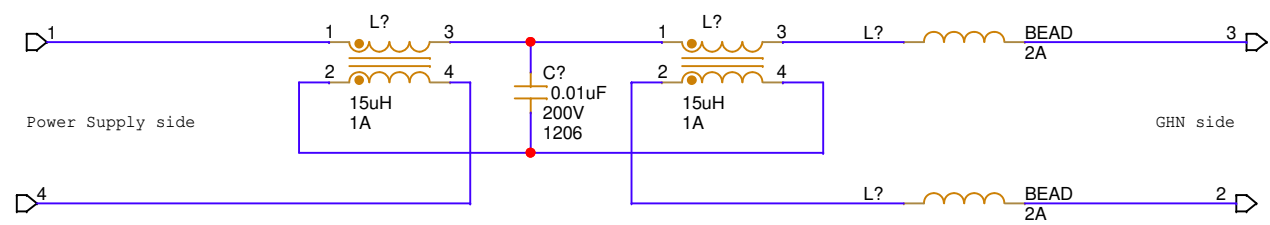

Title		
<Title>		
Size	Document Number	Rev
B	<Doc>	<Rev Co
Date:	Tuesday, November 29, 2022	Sheet 1 of 1

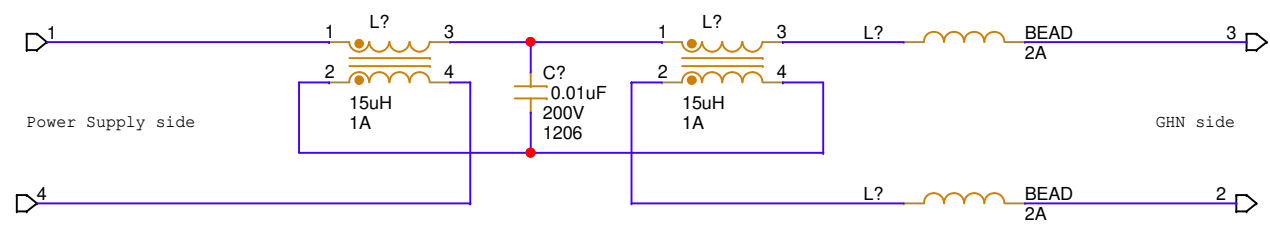

Title		
<Title>		
Size	Document Number	Rev
B	<Doc>	<Rev Co
Date:	Tuesday, November 29, 2022	Sheet 1 of 1

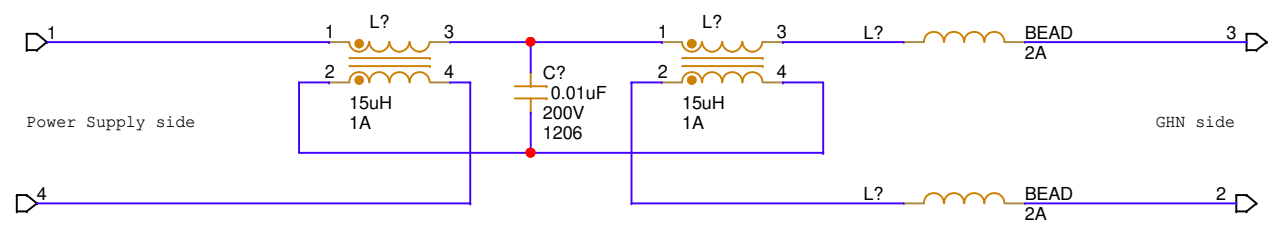

Title		
<Title>		
Size	Document Number	Rev
B	<Doc>	<Rev Co
Date:	Tuesday, November 29, 2022	Sheet 1 of 1

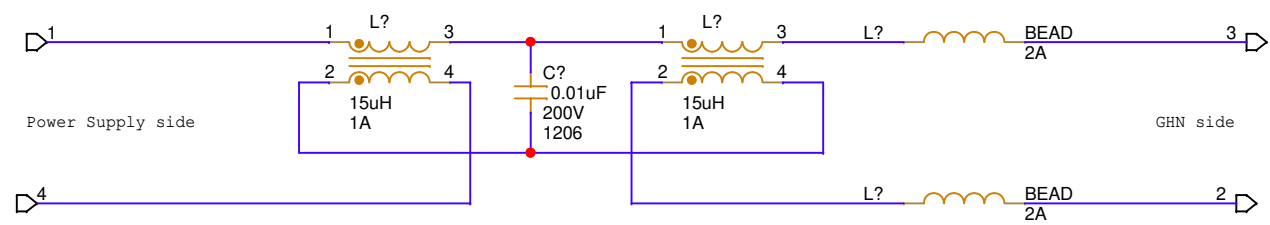

Title		
<Title>		
Size	Document Number	Rev
B	<Doc>	<Rev Co
Date:	Tuesday, November 29, 2022	Sheet 1 of 1

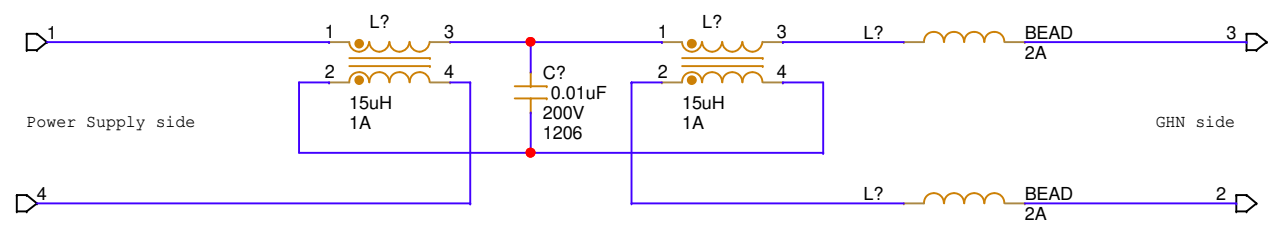

Title		
<Title>		
Size	Document Number	Rev
B	<Doc>	<Rev Co
Date:	Tuesday, November 29, 2022	Sheet 1 of 1

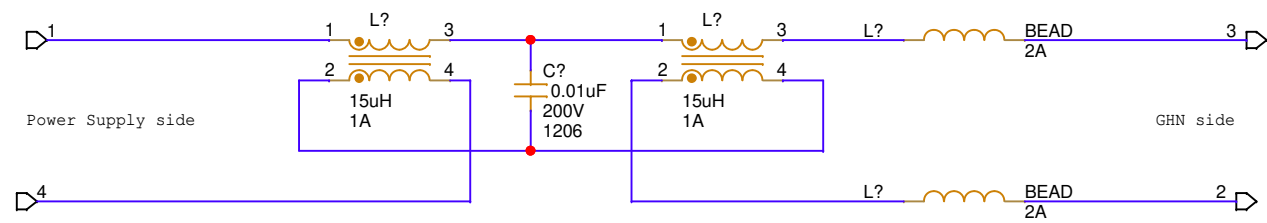

Title		
<Title>		
Size	Document Number	Rev
B	<Doc>	<Rev Co
Date:	Tuesday, November 29, 2022	Sheet 1 of 1



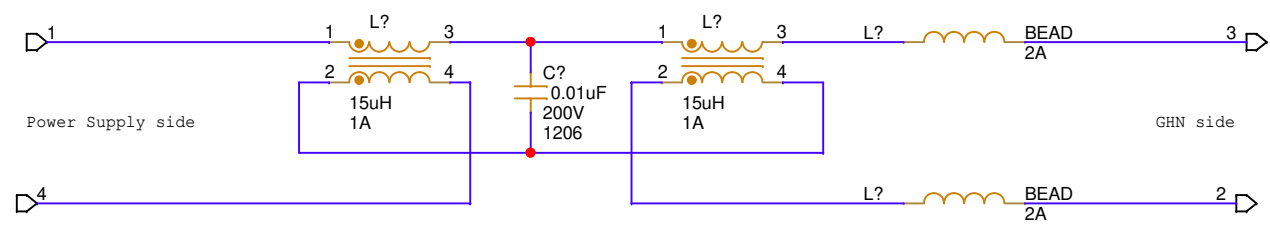

Title		
<Title>		
Size	Document Number	Rev
B	<Doc>	<Rev Co
Date:	Tuesday, November 29, 2022	Sheet 1 of 1

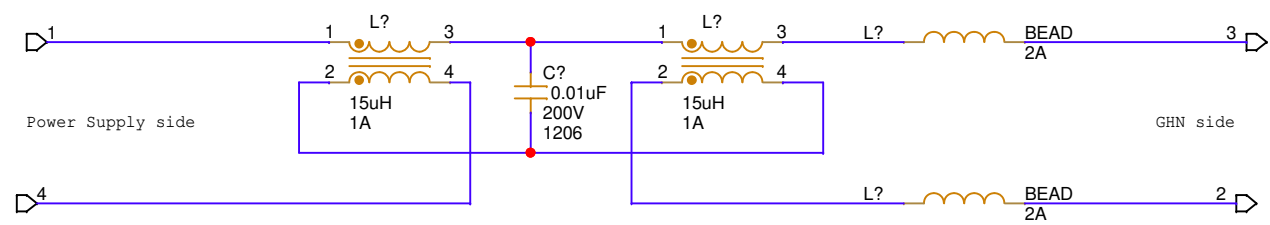

Title		
<Title>		
Size	Document Number	Rev
B	<Doc>	<Rev Co
Date:	Tuesday, November 29, 2022	Sheet 1 of 1

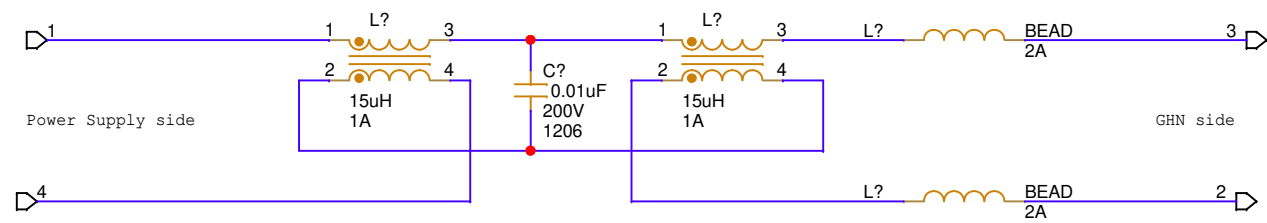

Title		
<Title>		
Size	Document Number	Rev
B	<Doc>	<Rev Co
Date:	Tuesday, November 29, 2022	Sheet 1 of 1

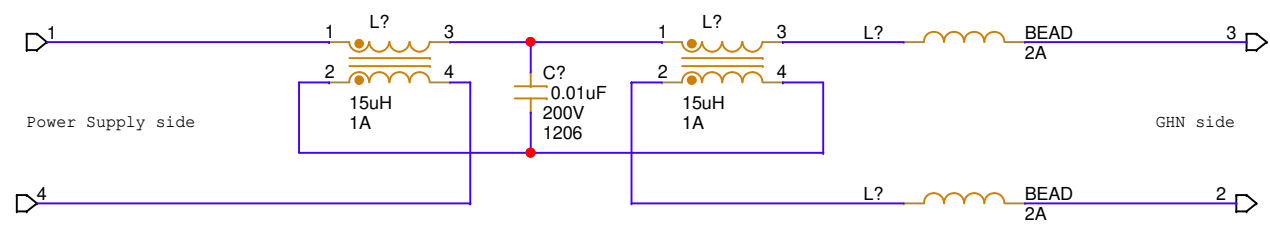

Title		
<Title>		
Size	Document Number	Rev
B	<Doc>	<Rev Co
Date:	Tuesday, November 29, 2022	Sheet 1 of 1

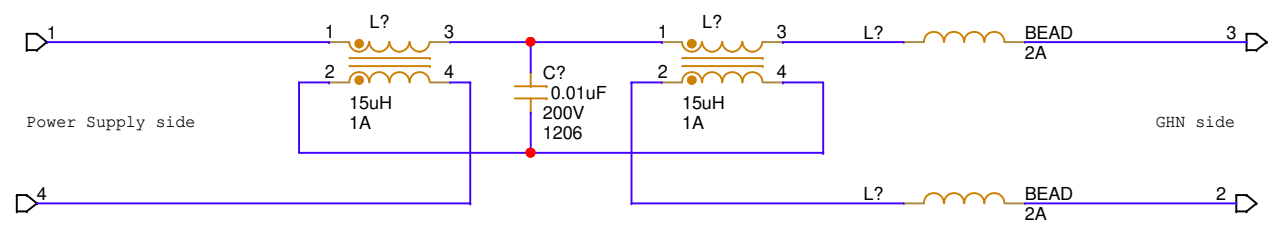

Title		
<Title>		
Size	Document Number	Rev
B	<Doc>	<Rev Co
Date:	Tuesday, November 29, 2022	Sheet 1 of 1

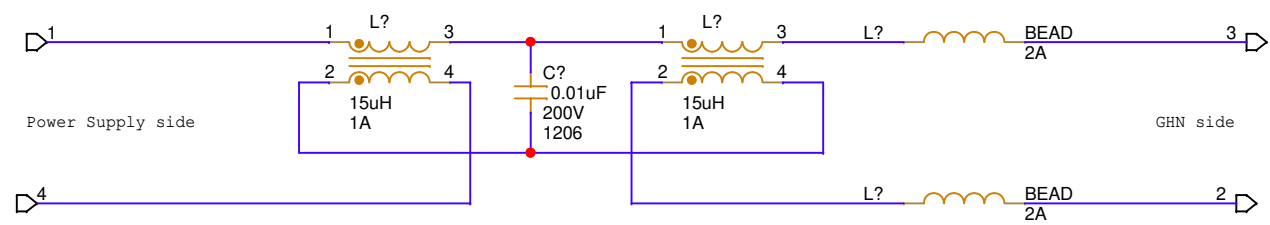

Title		
<Title>		
Size	Document Number	Rev
B	<Doc>	<Rev Co
Date:	Tuesday, November 29, 2022	Sheet 1 of 1

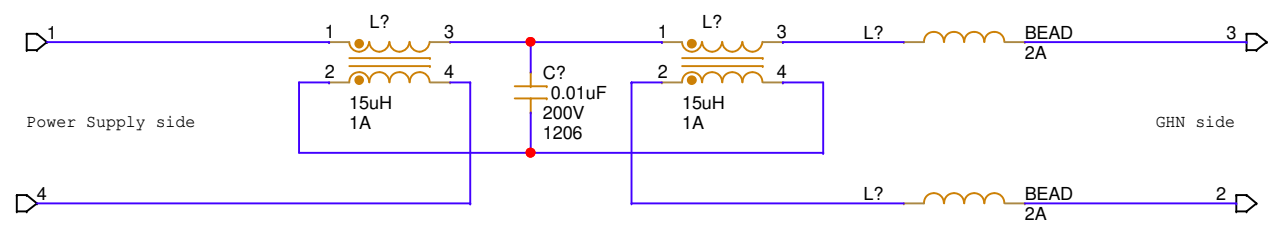

Title		
<Title>		
Size	Document Number	Rev
B	<Doc>	<Rev Co
Date:	Tuesday, November 29, 2022	Sheet 1 of 1

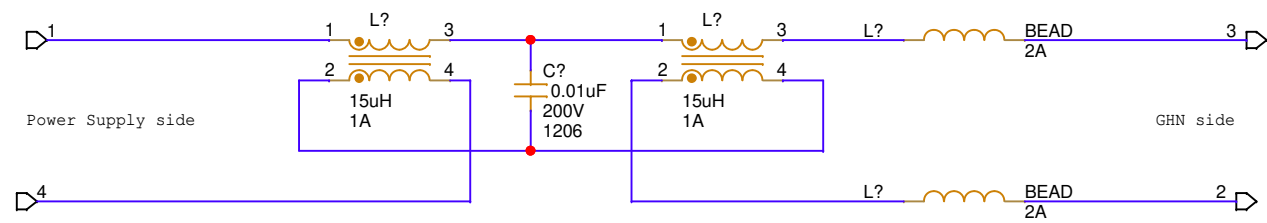

Title		
<Title>		
Size	Document Number	Rev
B	<Doc>	<Rev Co
Date:	Tuesday, November 29, 2022	Sheet 1 of 1



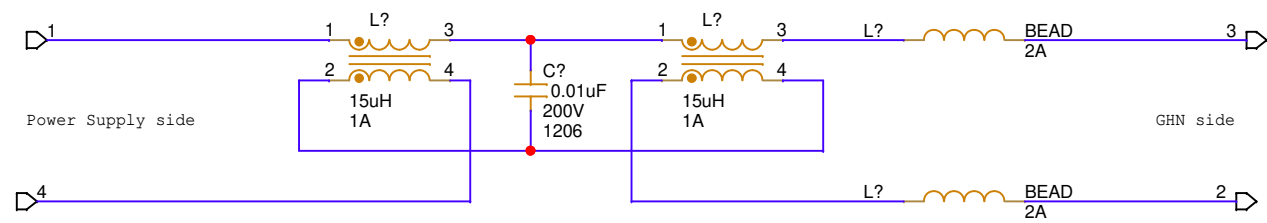

Title		
<Title>		
Size	Document Number	Rev
B	<Doc>	<Rev Co
Date:	Tuesday, November 29, 2022	Sheet 1 of 1

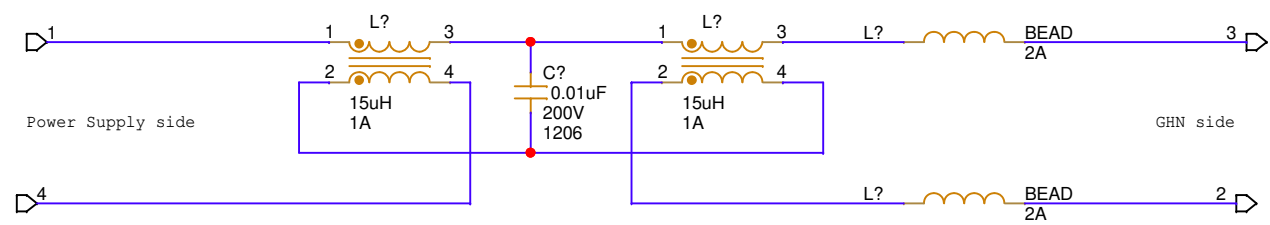

Title		
<Title>		
Size	Document Number	Rev
B	<Doc>	<Rev Co
Date:	Tuesday, November 29, 2022	Sheet 1 of 1

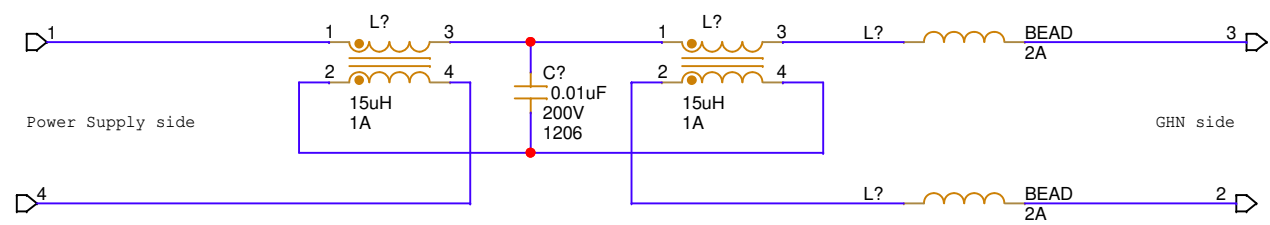

Title		
<Title>		
Size	Document Number	Rev
B	<Doc>	<Rev Co
Date:	Tuesday, November 29, 2022	Sheet 1 of 1

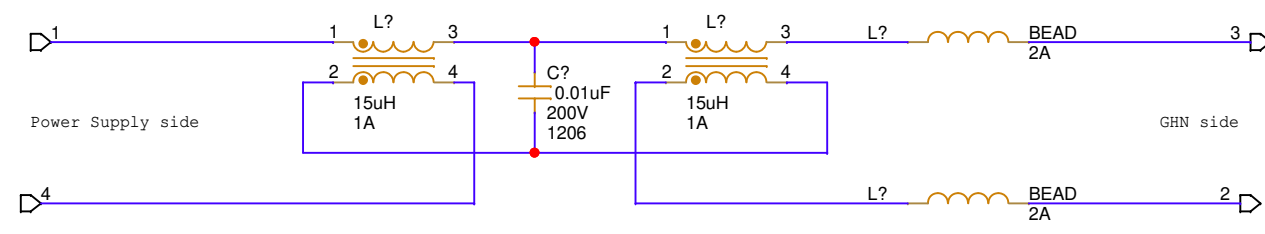

Title		
<Title>		
Size	Document Number	Rev
B	<Doc>	<Rev Co
Date:	Tuesday, November 29, 2022	Sheet 1 of 1

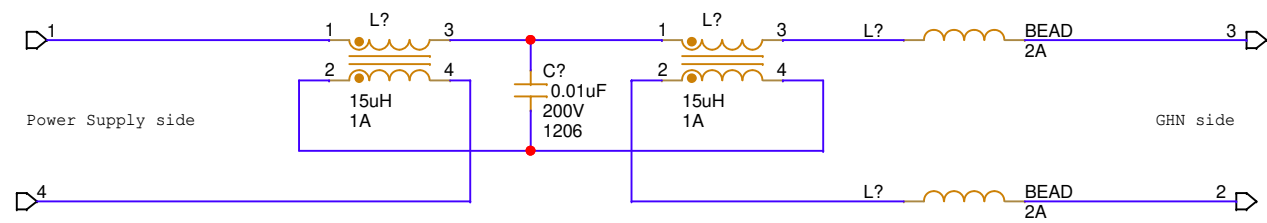

Title		
<Title>		
Size	Document Number	Rev
B	<Doc>	<Rev Co
Date:	Tuesday, November 29, 2022	Sheet 1 of 1

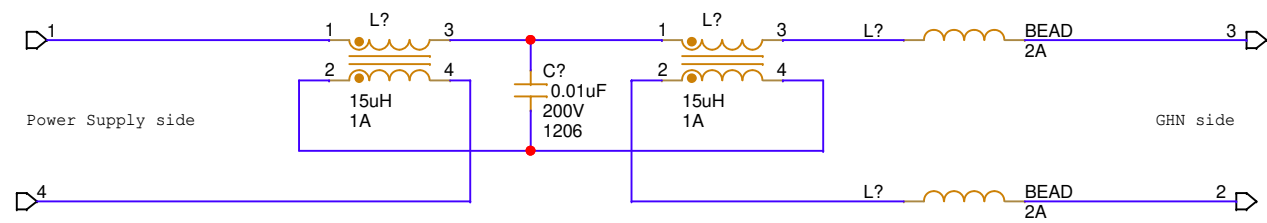

Title		
<Title>		
Size	Document Number	Rev
B	<Doc>	<Rev Co
Date:	Tuesday, November 29, 2022	Sheet 1 of 1

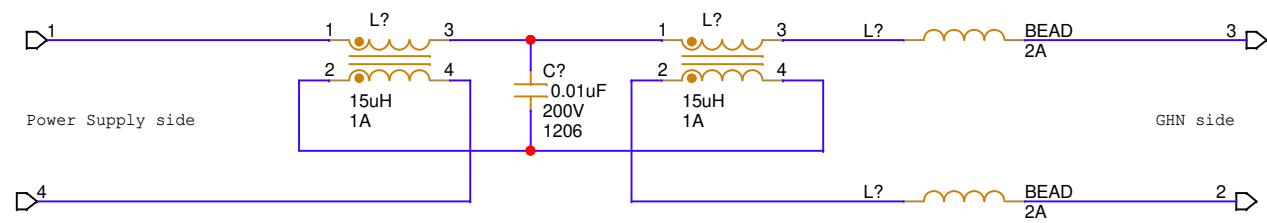

Title		
<Title>		
Size	Document Number	Rev
B	<Doc>	<Rev Co
Date:	Tuesday, November 29, 2022	Sheet 1 of 1

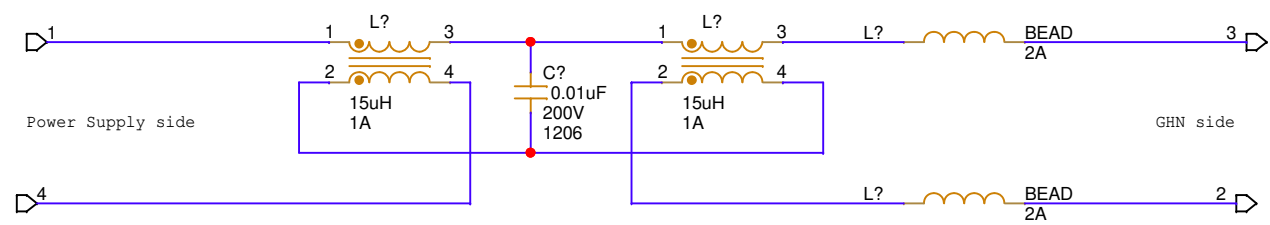

Title		
<Title>		
Size	Document Number	Rev
B	<Doc>	<Rev Co
Date:	Tuesday, November 29, 2022	Sheet 1 of 1



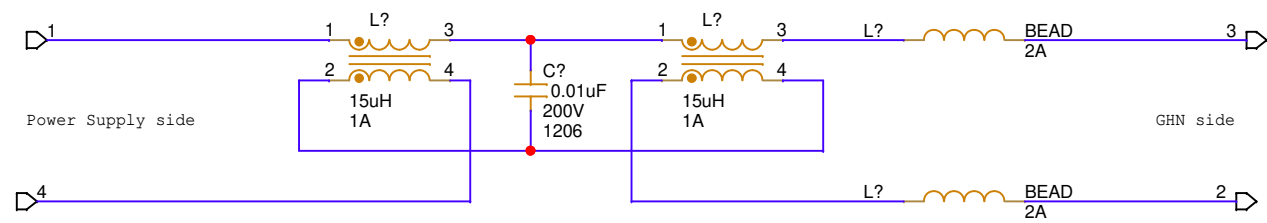

Title		
<Title>		
Size	Document Number	Rev
B	<Doc>	<Rev Co
Date:	Tuesday, November 29, 2022	Sheet 1 of 1

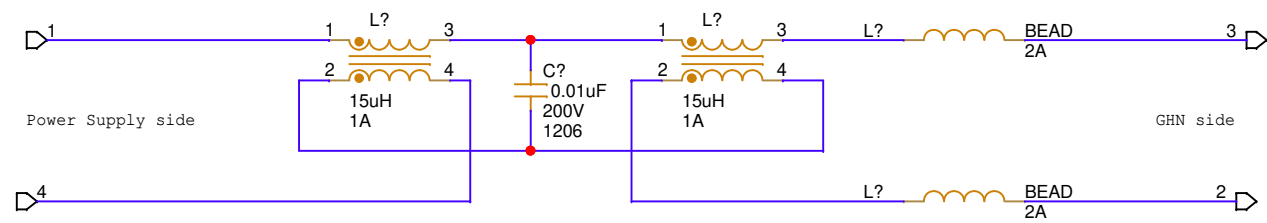

Title		
<Title>		
Size	Document Number	Rev
B	<Doc>	<Rev Co
Date:	Tuesday, November 29, 2022	Sheet 1 of 1

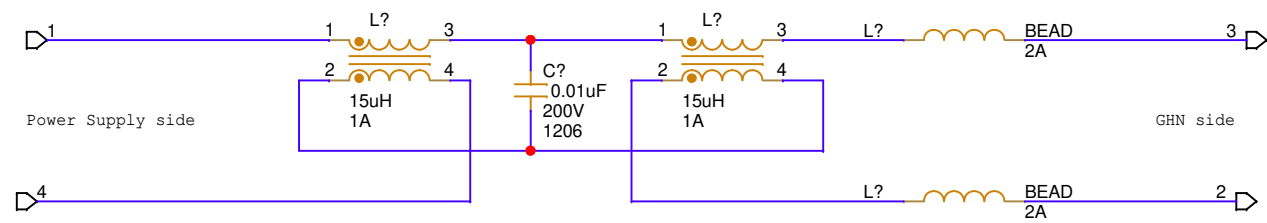

Title		
<Title>		
Size	Document Number	Rev
B	<Doc>	<Rev Co
Date:	Tuesday, November 29, 2022	Sheet 1 of 1

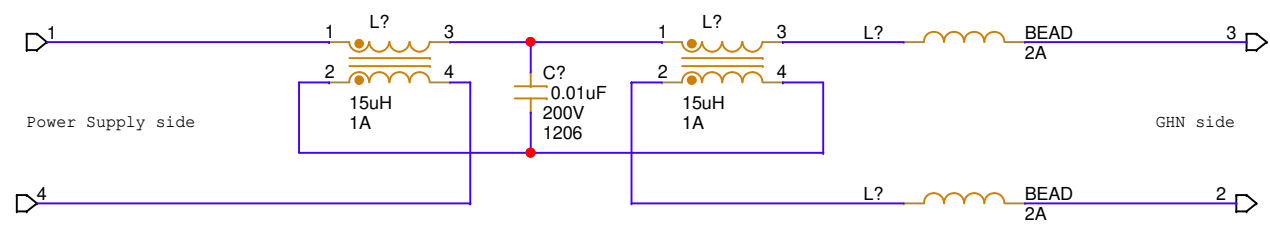

Title		
<Title>		
Size	Document Number	Rev
B	<Doc>	<Rev Co
Date:	Tuesday, November 29, 2022	Sheet 1 of 1

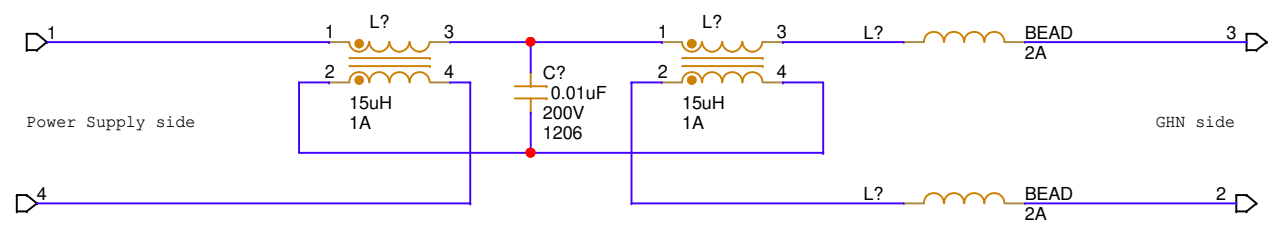

Title		
<Title>		
Size	Document Number	Rev
B	<Doc>	<Rev Co
Date:	Tuesday, November 29, 2022	Sheet 1 of 1

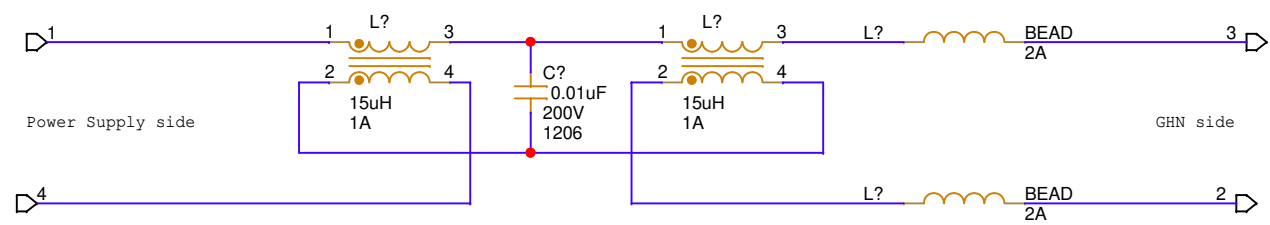

Title		
<Title>		
Size	Document Number	Rev
B	<Doc>	<Rev Co
Date:	Tuesday, November 29, 2022	Sheet 1 of 1

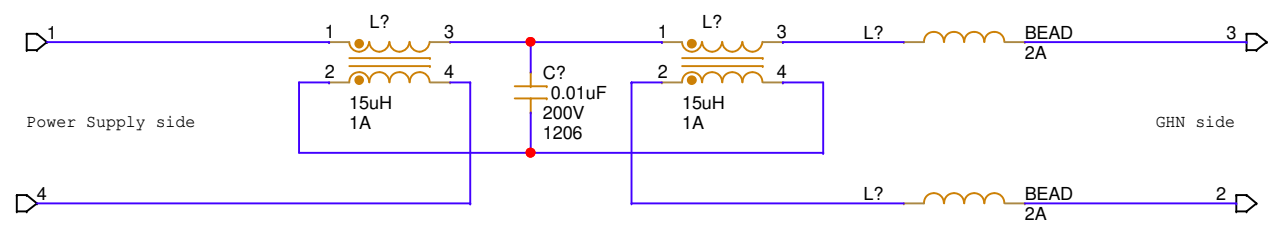

Title		
<Title>		
Size	Document Number	Rev
B	<Doc>	<Rev Co
Date:	Tuesday, November 29, 2022	Sheet 1 of 1

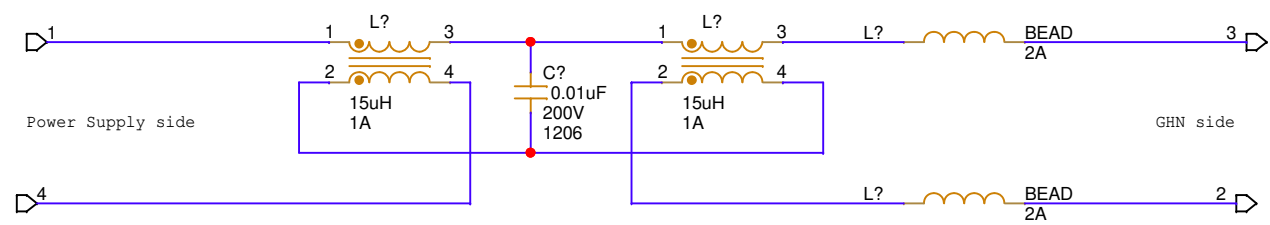

Title		
<Title>		
Size	Document Number	Rev
B	<Doc>	<Rev Co
Date:	Tuesday, November 29, 2022	Sheet 1 of 1



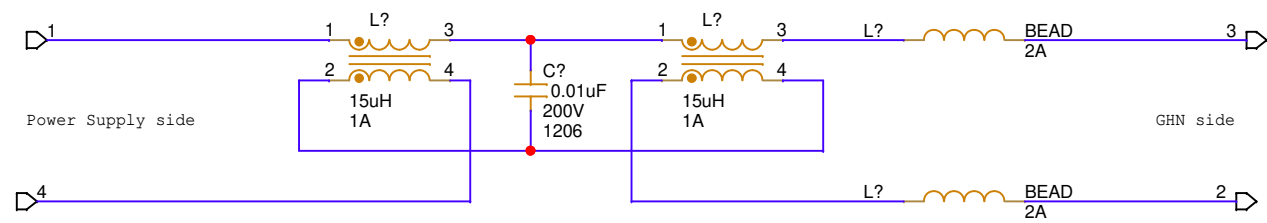

Title		
<Title>		
Size	Document Number	Rev
B	<Doc>	<Rev Co
Date:	Tuesday, November 29, 2022	Sheet 1 of 1

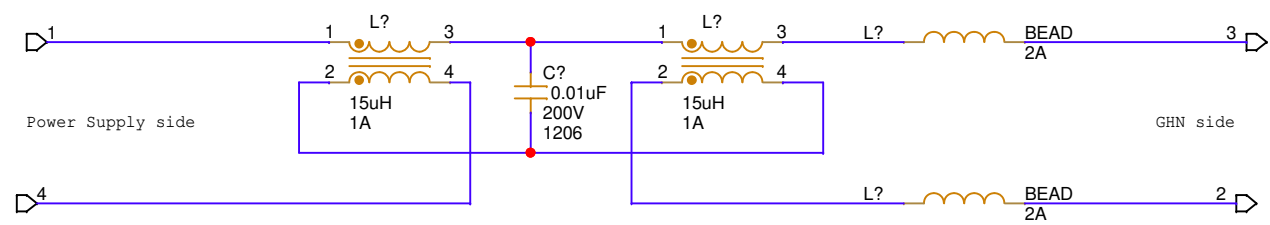

Title		
<Title>		
Size	Document Number	Rev
B	<Doc>	<Rev Co
Date:	Tuesday, November 29, 2022	Sheet 1 of 1

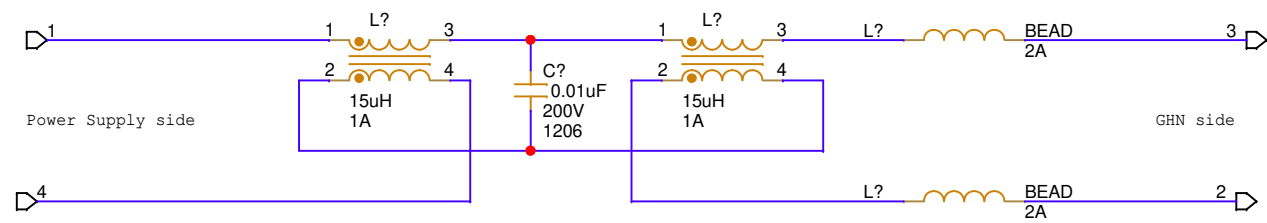

Title		
<Title>		
Size	Document Number	Rev
B	<Doc>	<Rev Co
Date:	Tuesday, November 29, 2022	Sheet 1 of 1

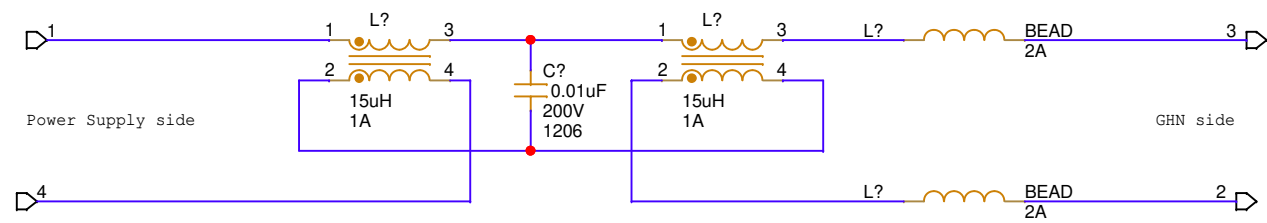

Title		
<Title>		
Size	Document Number	Rev
B	<Doc>	<Rev Co
Date:	Tuesday, November 29, 2022	Sheet 1 of 1

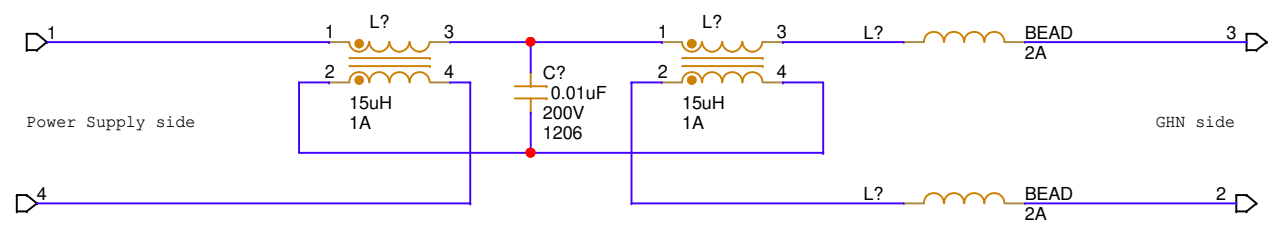

Title		
<Title>		
Size	Document Number	Rev
B	<Doc>	<Rev Co
Date:	Tuesday, November 29, 2022	Sheet 1 of 1

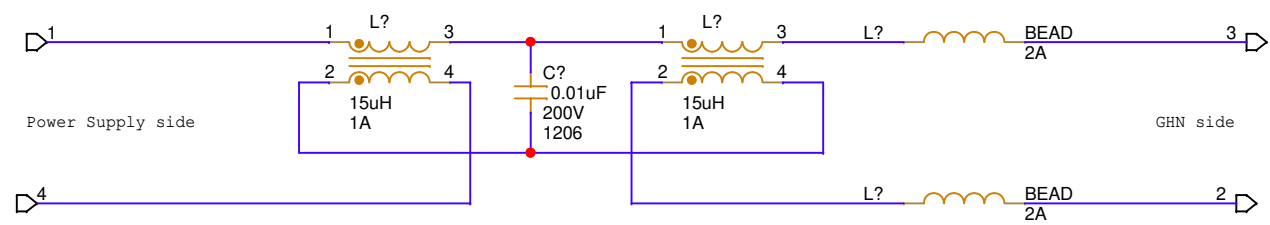

Title		
<Title>		
Size	Document Number	Rev
B	<Doc>	<Rev Co
Date:	Tuesday, November 29, 2022	Sheet 1 of 1

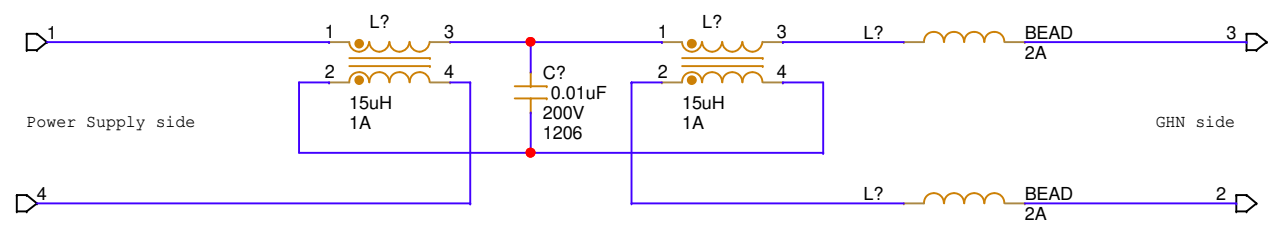

Title		
<Title>		
Size	Document Number	Rev
B	<Doc>	<Rev Co
Date:	Tuesday, November 29, 2022	Sheet 1 of 1

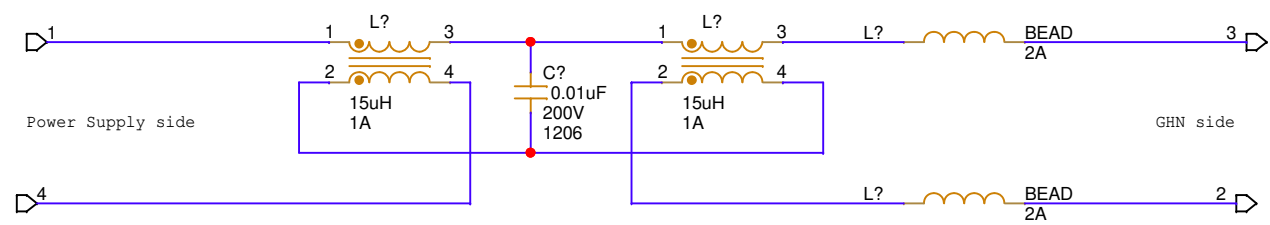

Title		
<Title>		
Size	Document Number	Rev
B	<Doc>	<Rev Co
Date:	Tuesday, November 29, 2022	Sheet 1 of 1



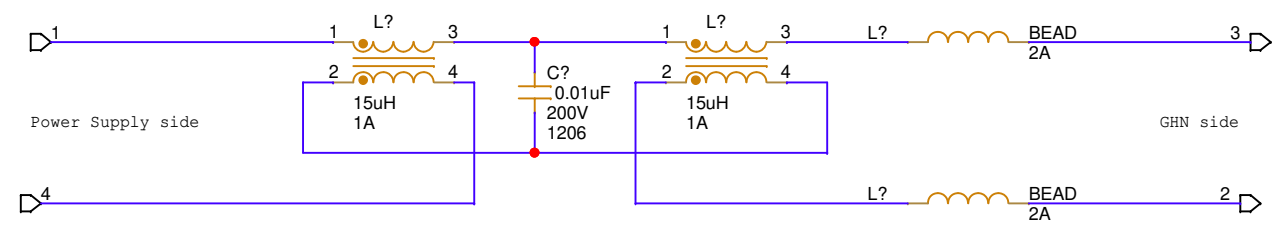

Title		
<Title>		
Size	Document Number	Rev
B	<Doc>	<Rev Co
Date:	Tuesday, November 29, 2022	Sheet 1 of 1

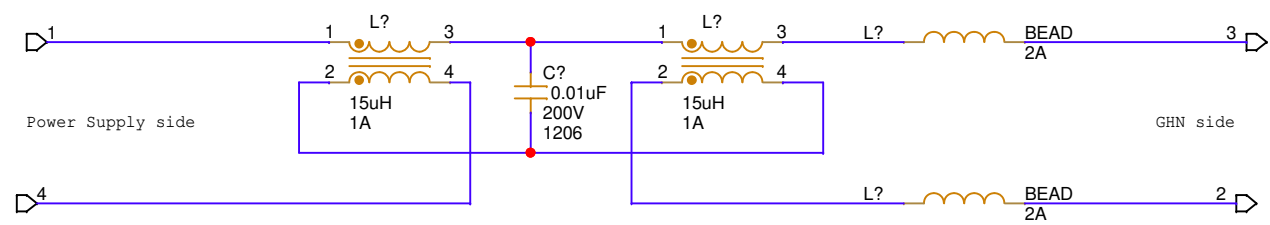

Title		
<Title>		
Size	Document Number	Rev
B	<Doc>	<Rev Co
Date:	Tuesday, November 29, 2022	Sheet 1 of 1

# Controller

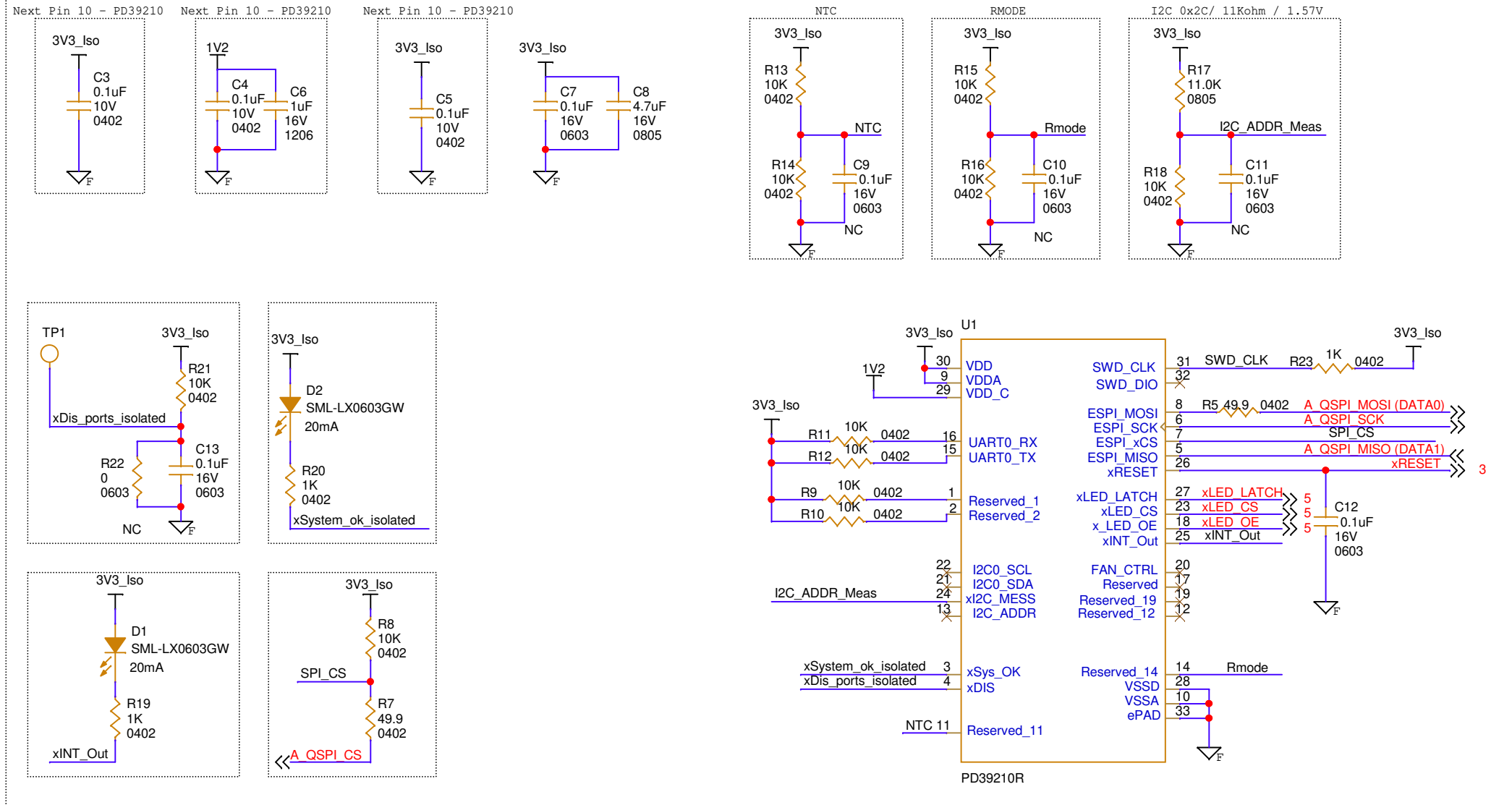

OFF-PAGEau chip ATMEL?

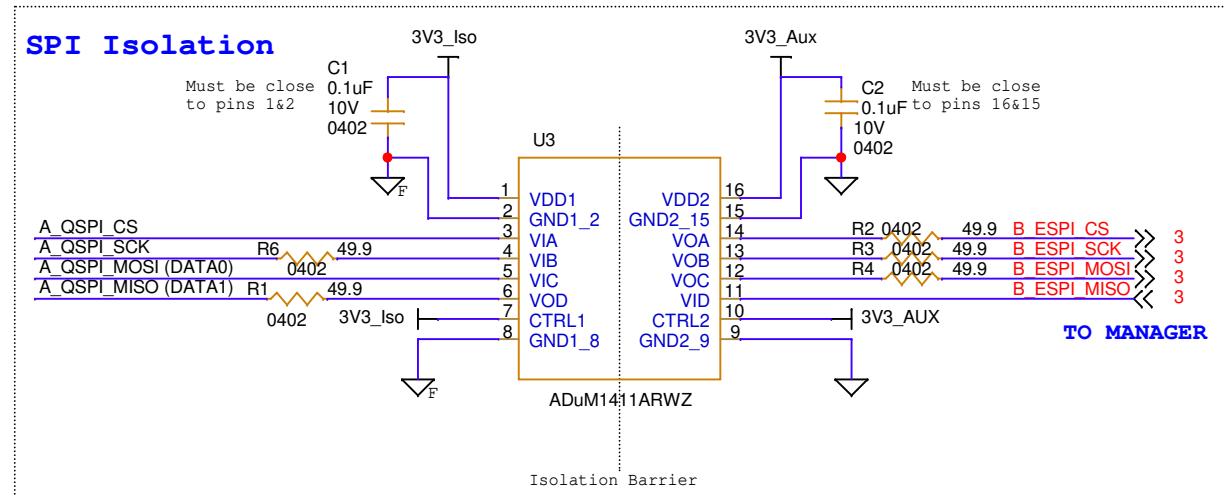

Cartouche

Title		
<Title>		
Size	Document Number	Rev
B	<Doc>	<Rev Co
Date:	Monday, December 05, 2022	Sheet 2 of 1

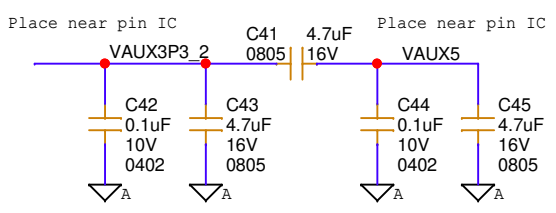
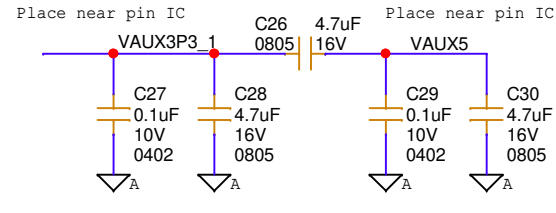
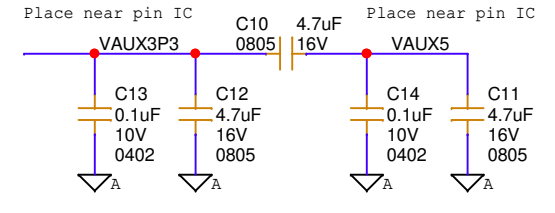
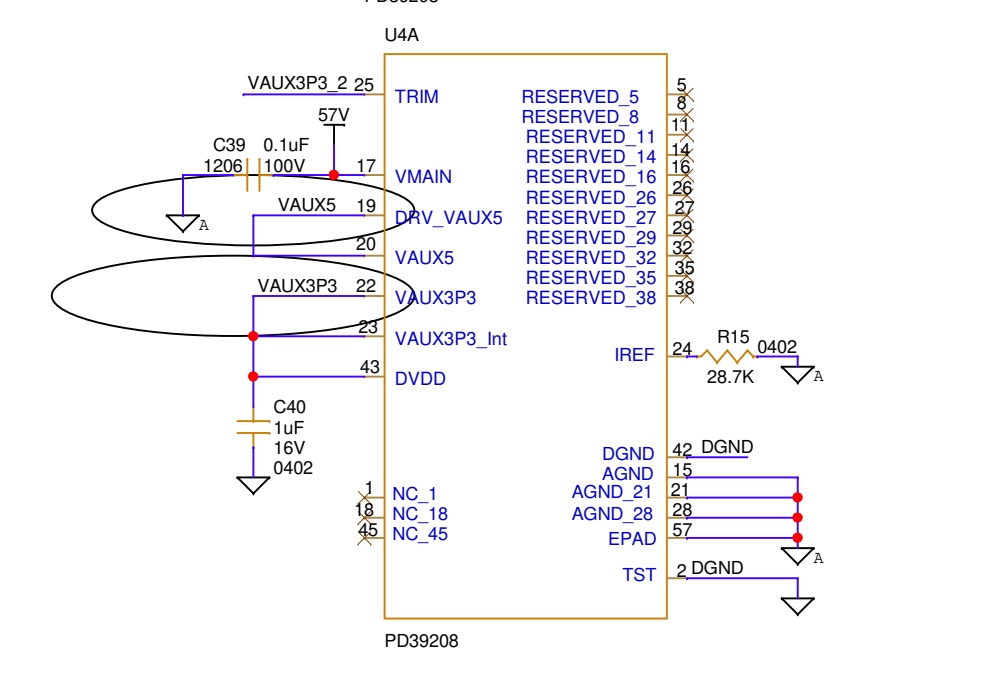
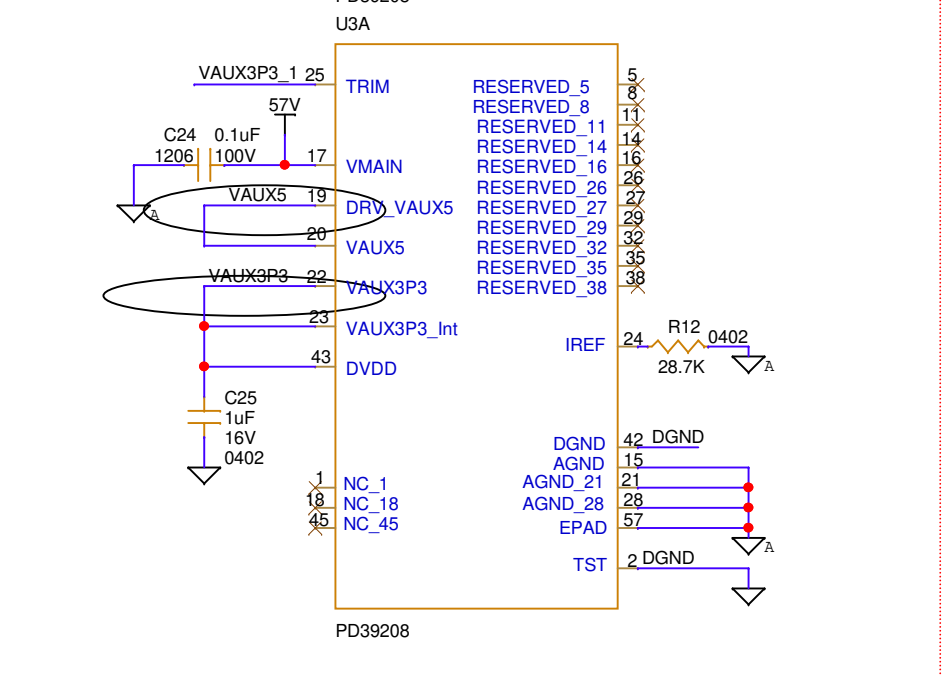
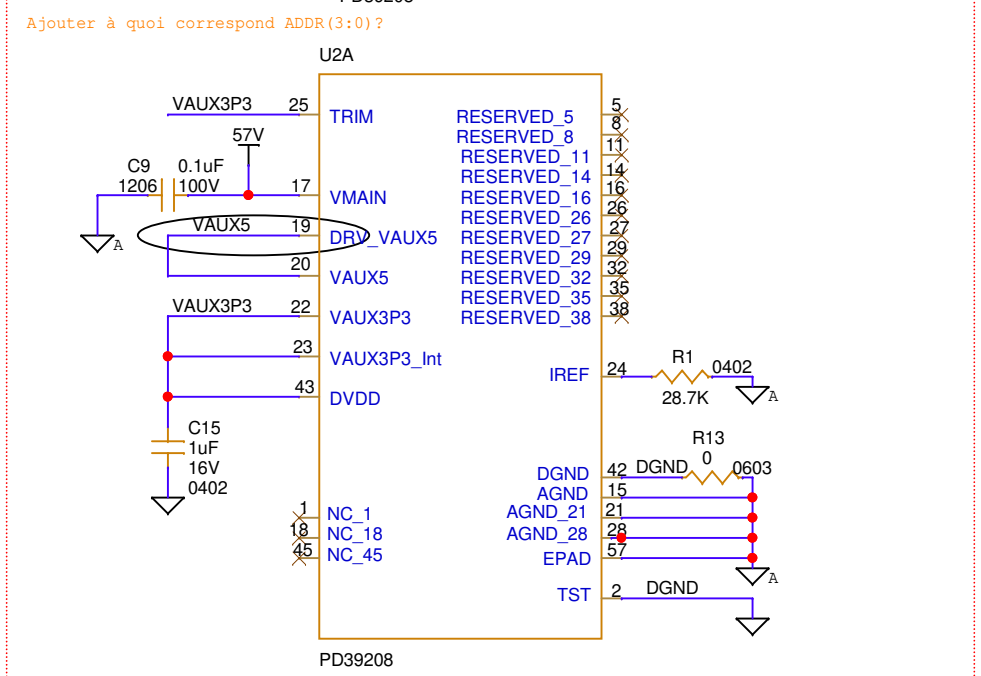
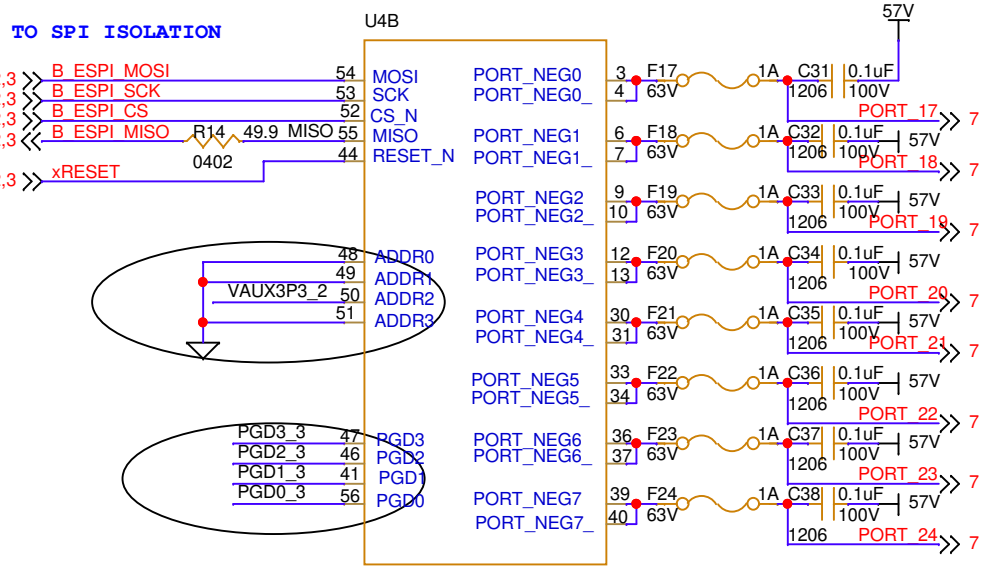
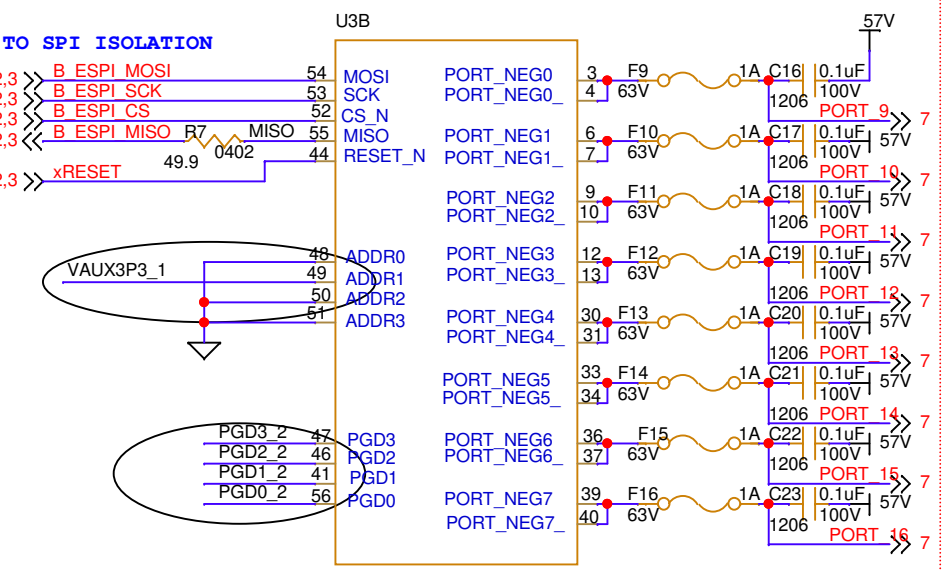
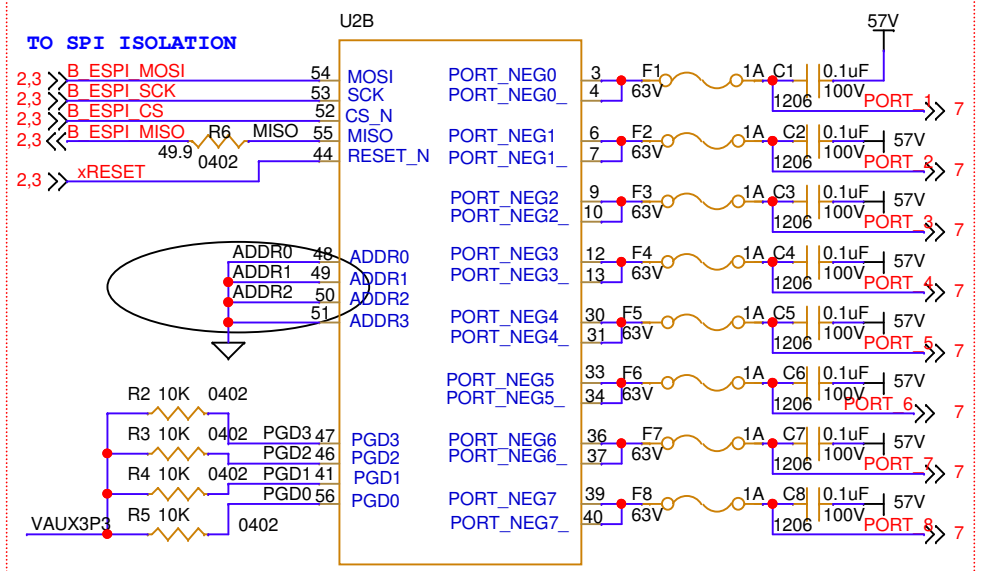

mettre la résistance sur DGND?

PORT 1 to 8

PORT 9 to 16

PORT 17 to 24

# SPLIT 57VA vs 57VB

Cartouche

Title		
<Title>		
Size B	Document Number	Rev
	<Doc>	<Rev Co
Date:	Monday, December 05, 2022	Sheet 3 of 1

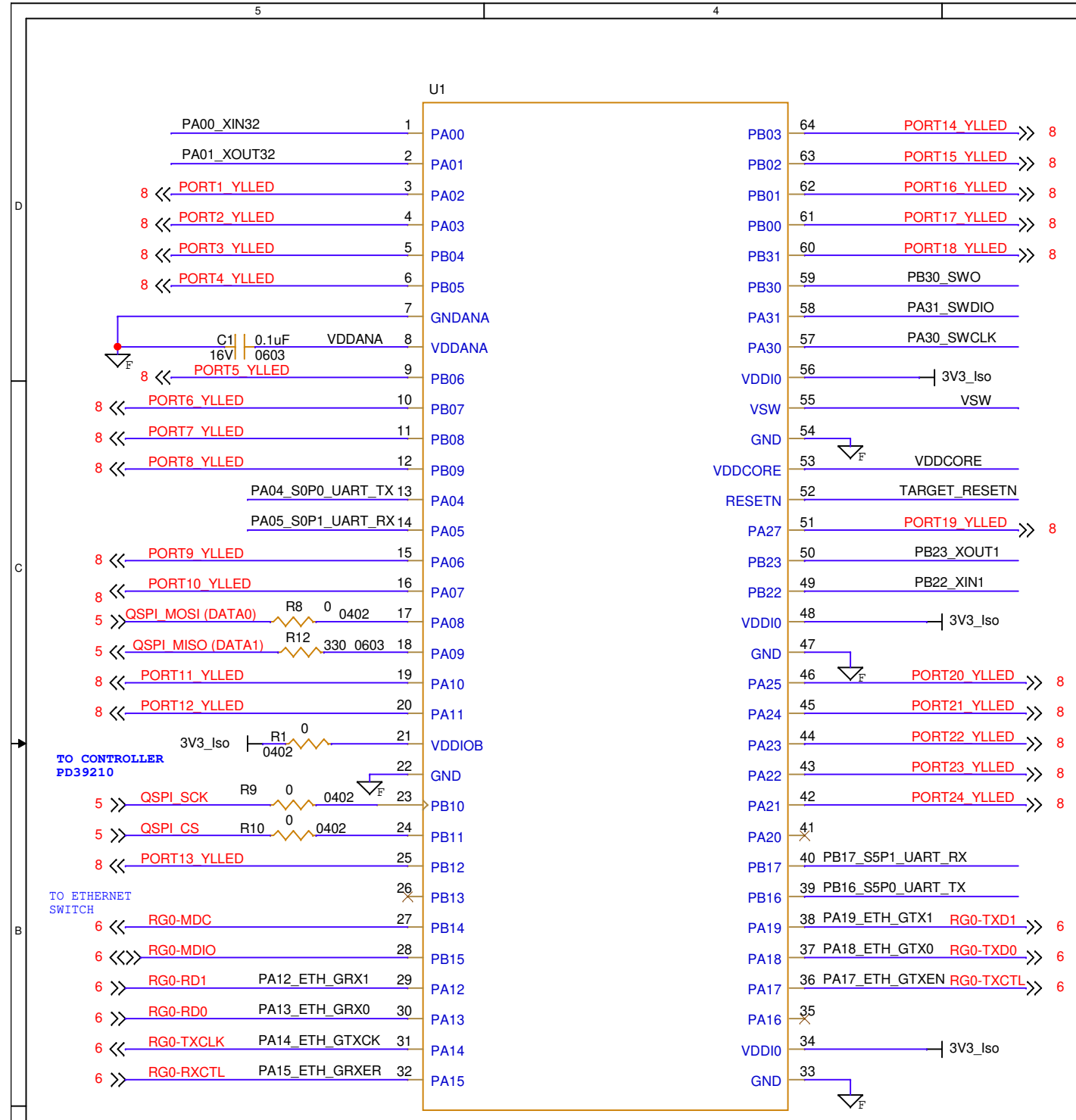

PA08,PA09,PB10 et PB11 sont une interface SPI sur le ATMEL?

Close to each VDDIO pair

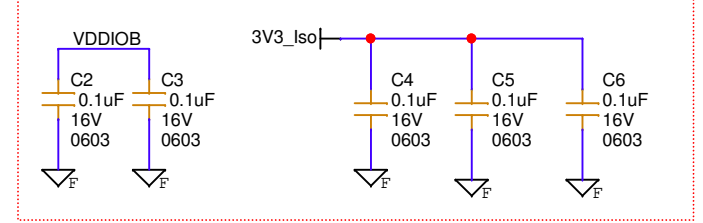

VDDIO

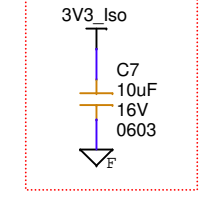

Close to VDDCORE

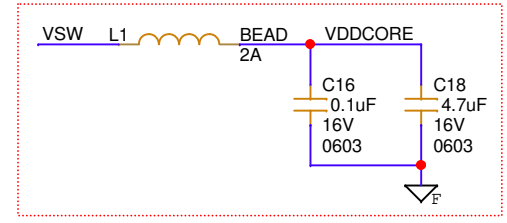

VDDANA Filter

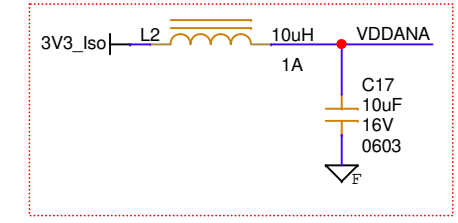

32.768 kHz Crystal

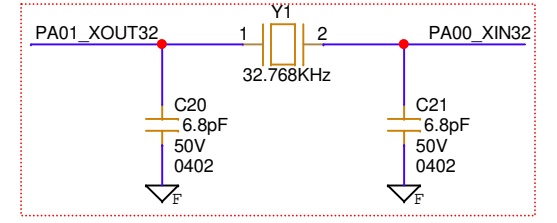

RESET with current limit and noise filter

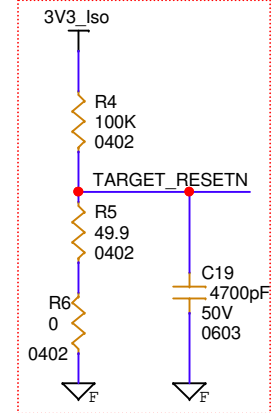

I2C PULL-UP

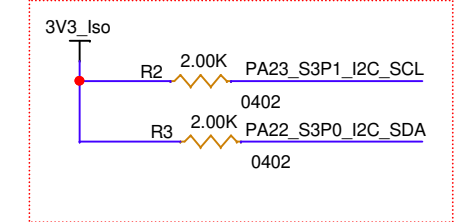

12 MHz Crystal

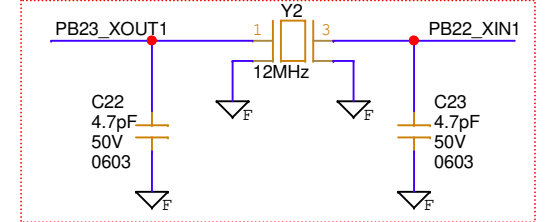

Connector for connecting an external programmer

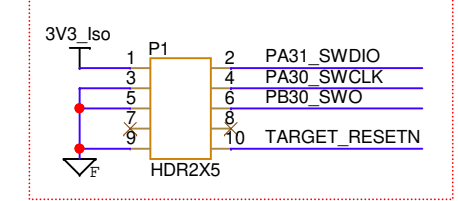

Il y a quelquechose de bizarre avec ce circuit

TO ETHERNET SWITCH

CARTOUCHE

Title		<Title>
Size B	Document Number	Rev <Rev Co
Date:	Monday, December 05, 2022	Sheet 4 of 1

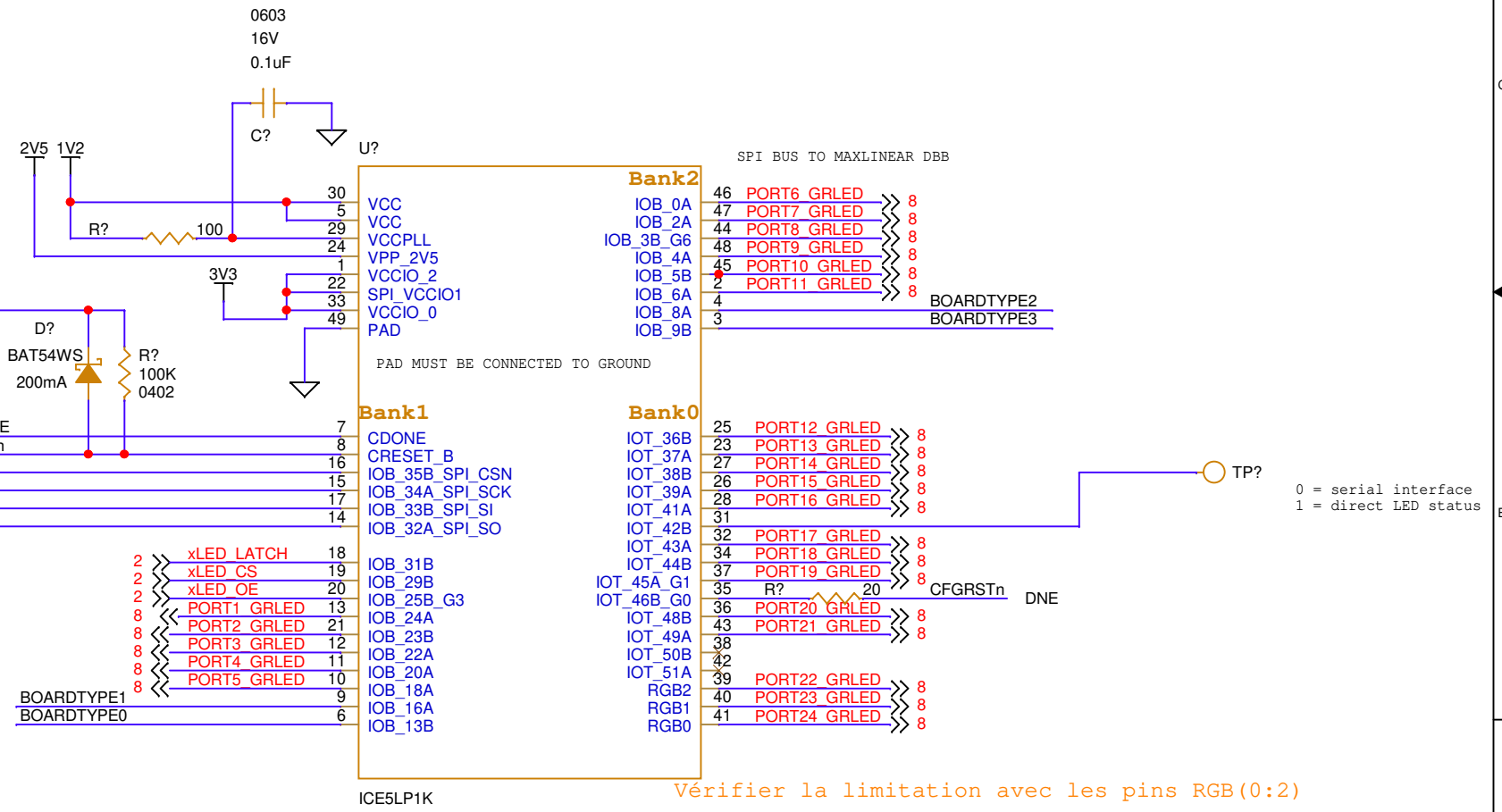
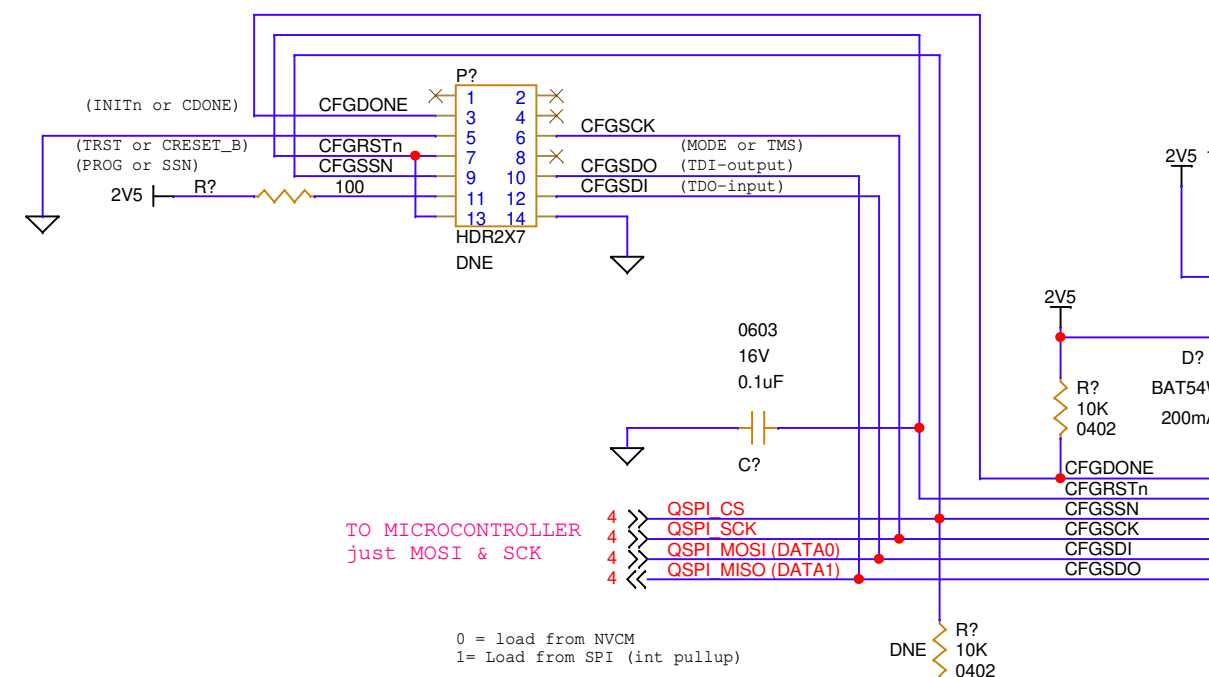
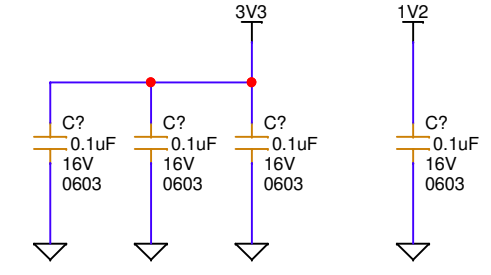
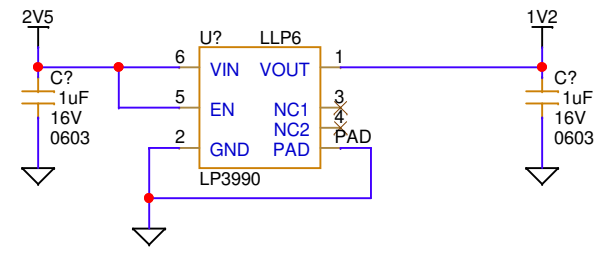
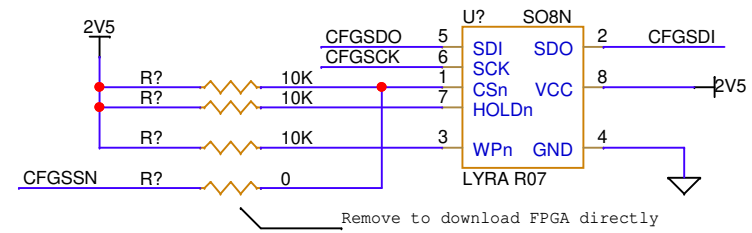

0 = load from NVCM  
1 = Load from SPI (int pullup)

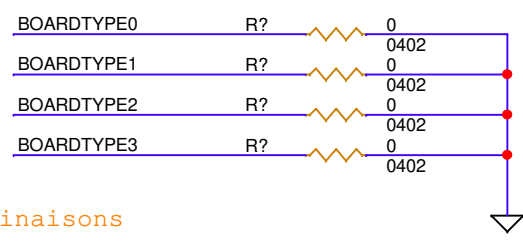

Boardtype	Boardtype	Boardtype	Boardtype
0000	G1002-C	1000	TBD
0001	G1002-M	1001	TBD
0010	G1002-C+	1010	TBD
0011	G1002-M+	1011	TBD
0100	G1004-C	1100	TBD
0101	G1004-M	1101	TBD
0110	G1004-C+	1110	TBD
0111	G1004-M+	1111	G2002-M+

Il faut revoir si on a besoin d'autant de combinaisons

Title <b>G1002-C/C+ CPE</b>		Block <b>LYRA FPGA</b>	
POSITRON CONFIDENTIAL		Dwg No <b>SCH-0483-003</b>	Rev <b>R01</b>
Size <b>B</b>	Date Monday, December 05, 2022	Sheet 5 of 14	

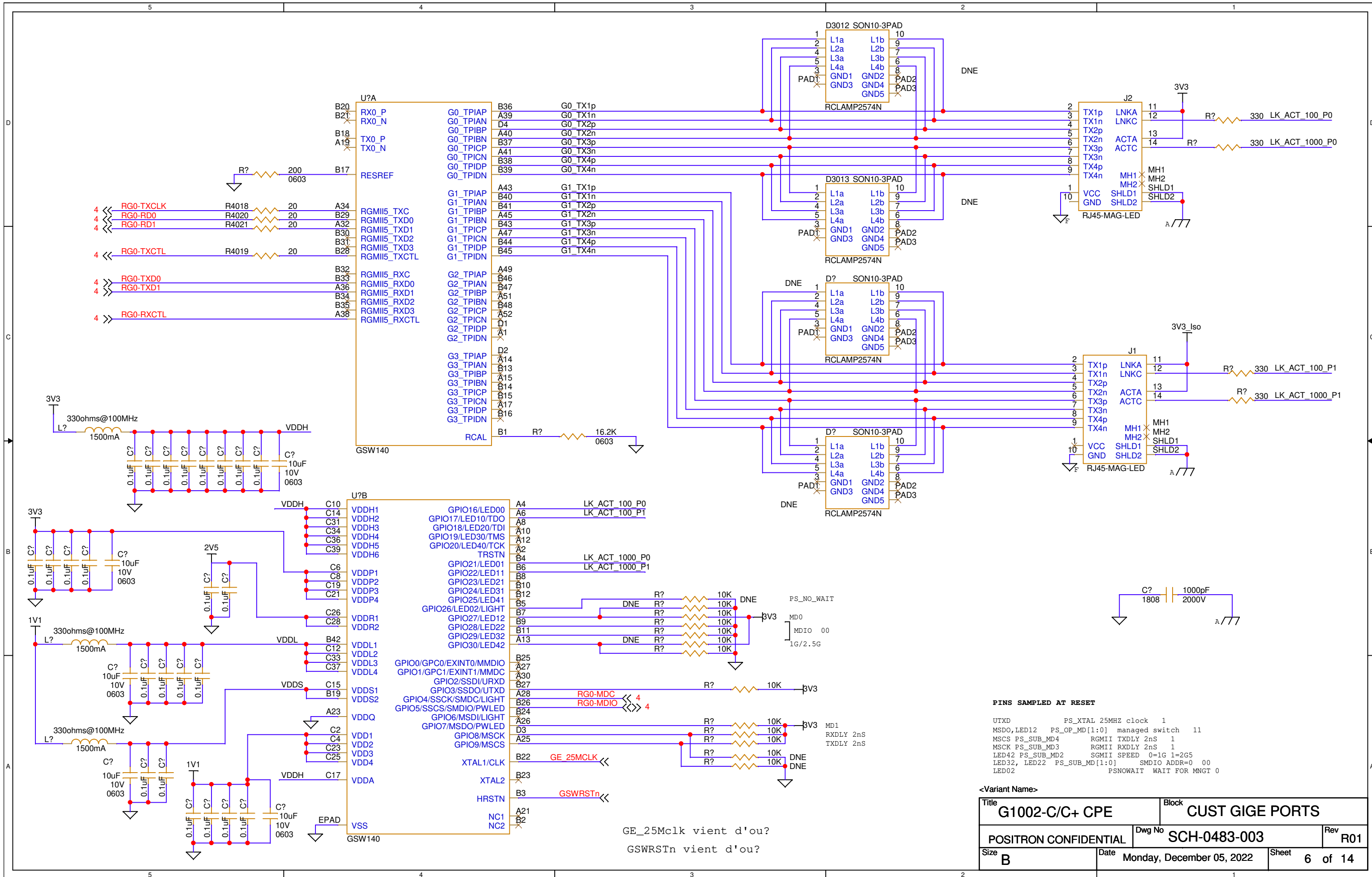

**PINS SAMPLED AT RESET**

```

UTXD      PS_XTAL 25MHz clock 1
MSDO,LED12 PS_OP_MD[1:0] managed switch 11
MSCS PS_SUB_MD4 RGMII TXDLY 2ns 1
MSCK PS_SUB_MD3 RGMII RXDLY 2ns 1
LED42 PS_SUB_MD2 SGMII SPEED 0=1G 1=2G5
LED32, LED22 PS_SUB_MD[1:0] SMDIO ADDR=0 00
LED02      PSNOWAIT WAIT FOR MNGT 0
  
```

Title <b>G1002-C/C+ CPE</b>		Block <b>CUST GIGE PORTS</b>	
POSITRON CONFIDENTIAL		Dwg No <b>SCH-0483-003</b>	Rev <b>R01</b>
Size <b>B</b>	Date <b>Monday, December 05, 2022</b>	Sheet <b>6 of 14</b>	

GE\_25Mclk vient d'ou?  
GSWRSTn vient d'ou?



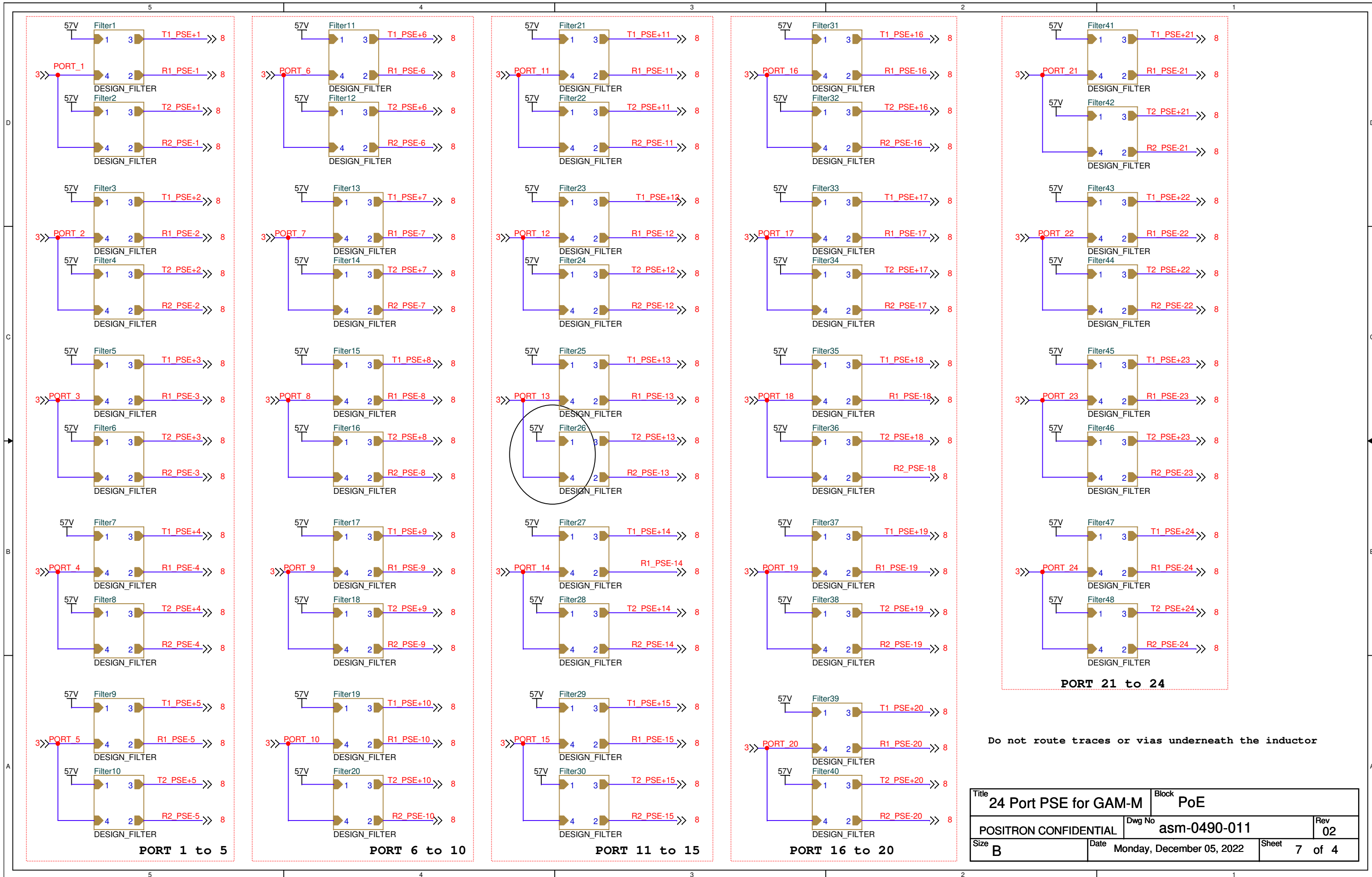

Do not route traces or vias underneath the inductor

Title <b>24 Port PSE for GAM-M</b>		Block <b>PoE</b>	
POSITRON CONFIDENTIAL		Dwg No <b>asm-0490-011</b>	Rev <b>02</b>
Size <b>B</b>	Date Monday, December 05, 2022	Sheet 7 of 4	



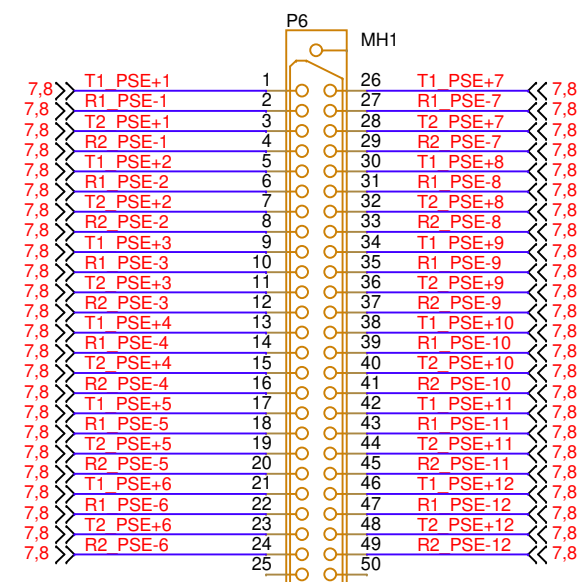
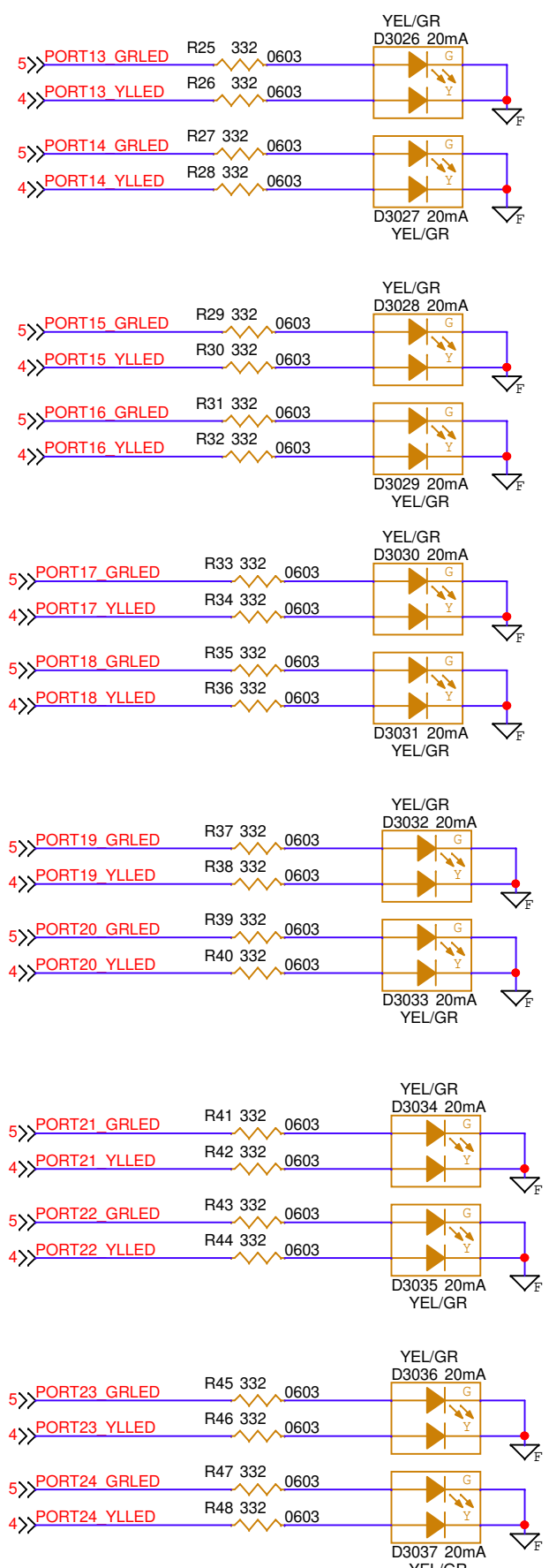
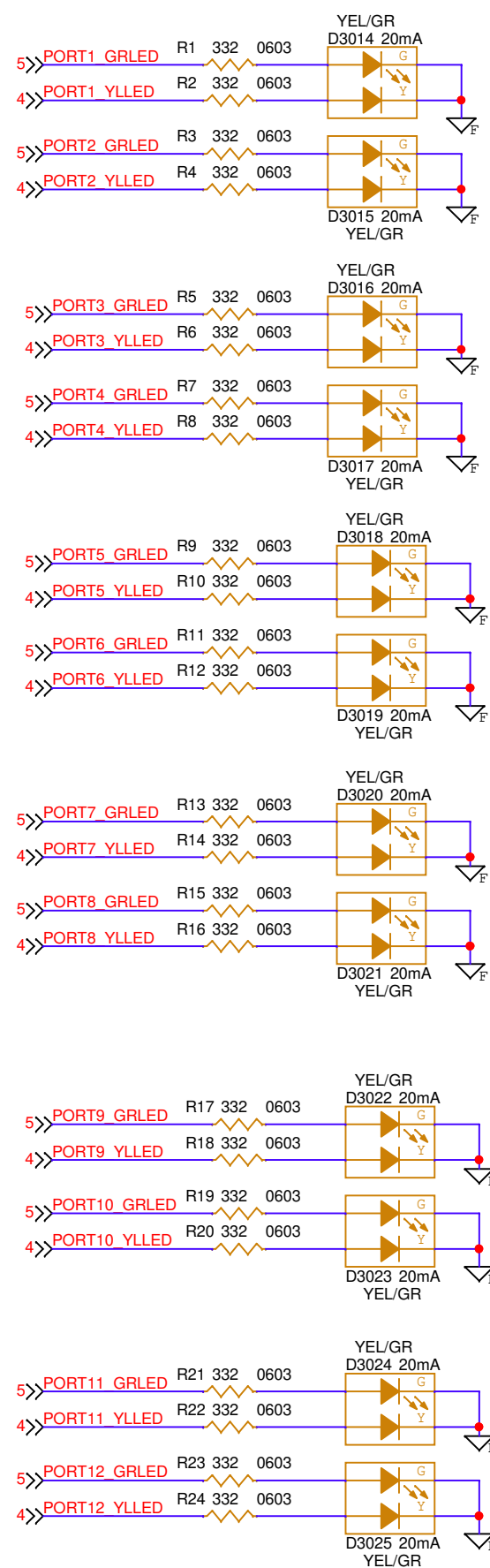

Mauvais pinout pour RJ21 (À corriger)  
 1=Rx\_1\_1, 26=Tx\_1\_1  
 2=Rx\_1\_2, 27=Tx\_1\_2...

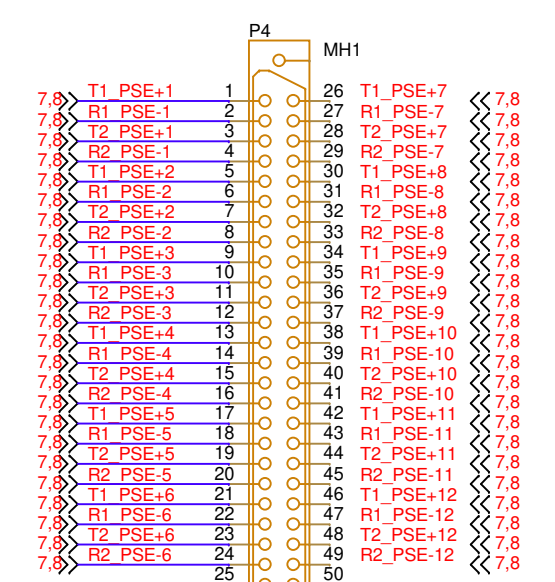

Il manque les attributs DIFFERENTIAL\_PAIR

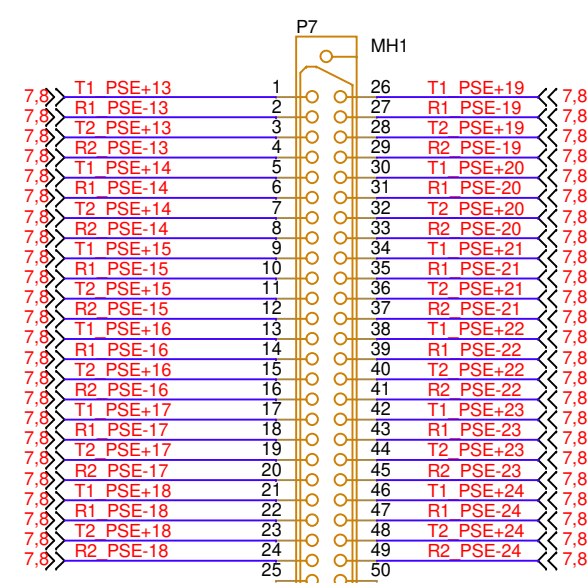

TELCO-M-ST-2X25-SD  
 Plug - Front Side

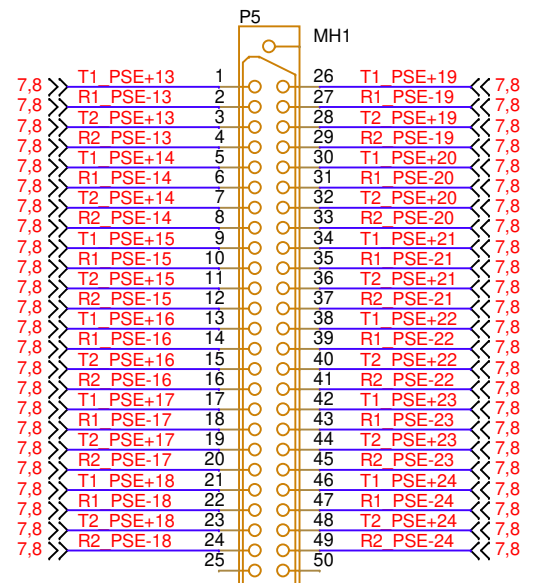

TELCO-F-ST-2X25-SD  
 Receptacle - Rear Side

Green LED from FPGA  
 Yellow LED from Microcontroller

Title <Title>		
Size B	Document Number <Doc>	Rev <Rev Co>
Date:	Monday, December 05, 2022	Sheet 8 of 1

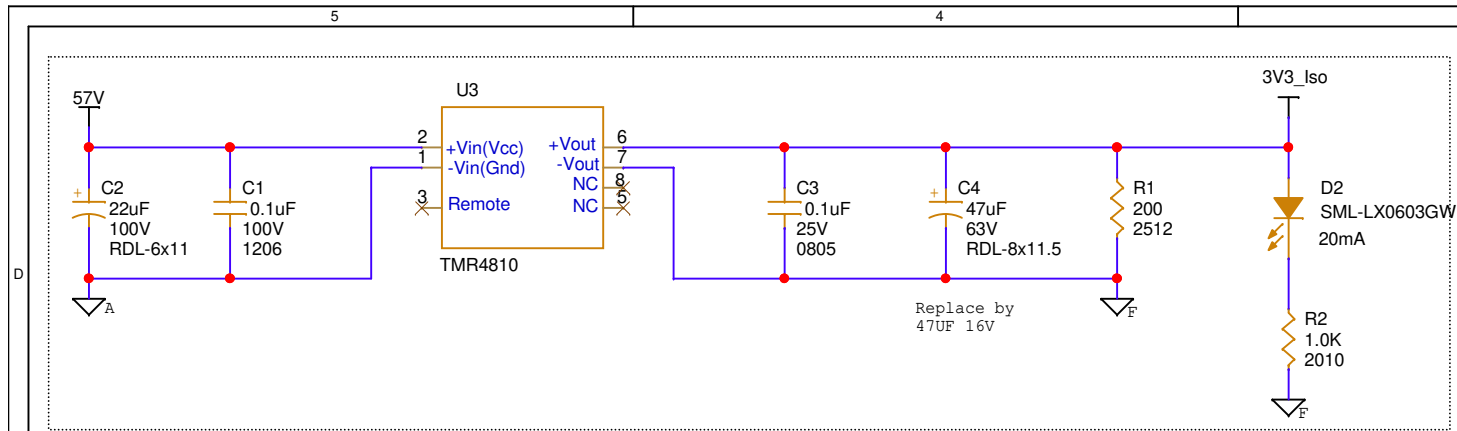

Trop couteux - Design avec composants discretes

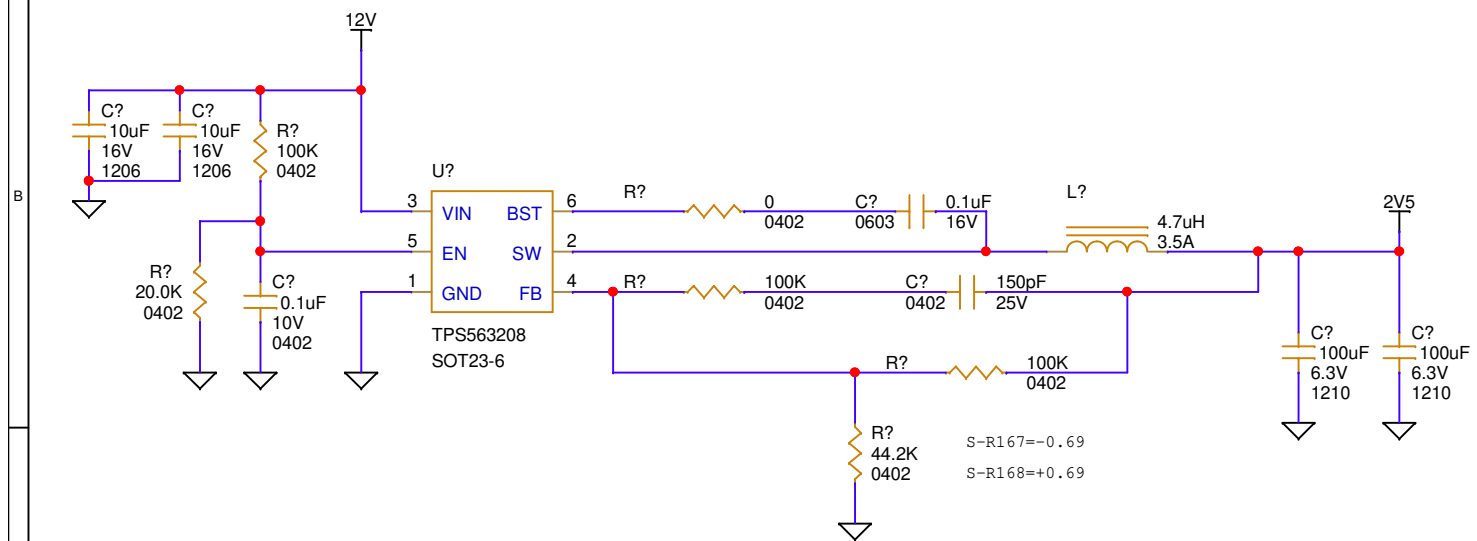
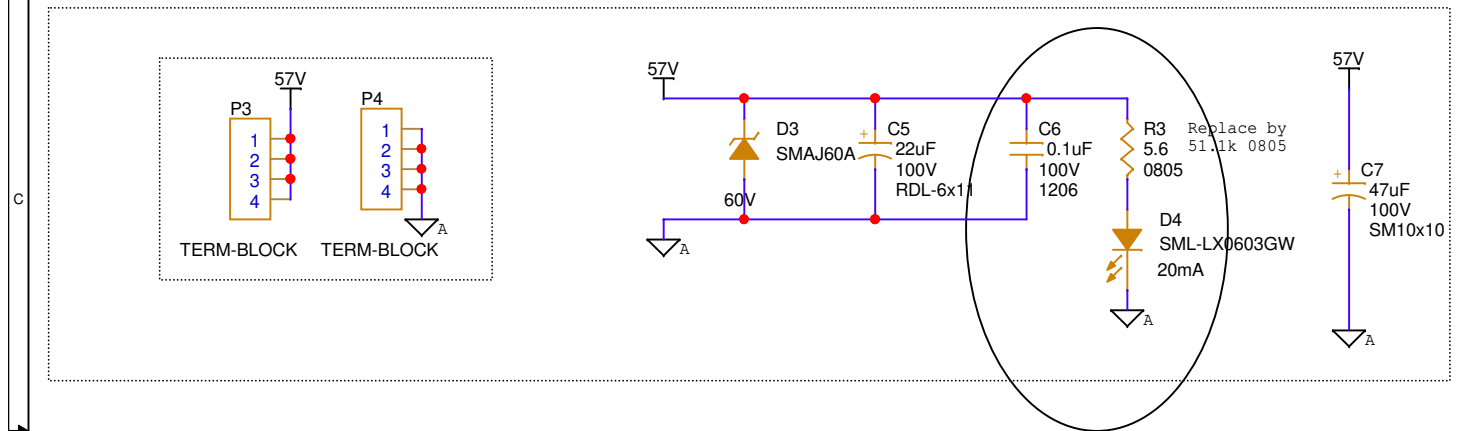
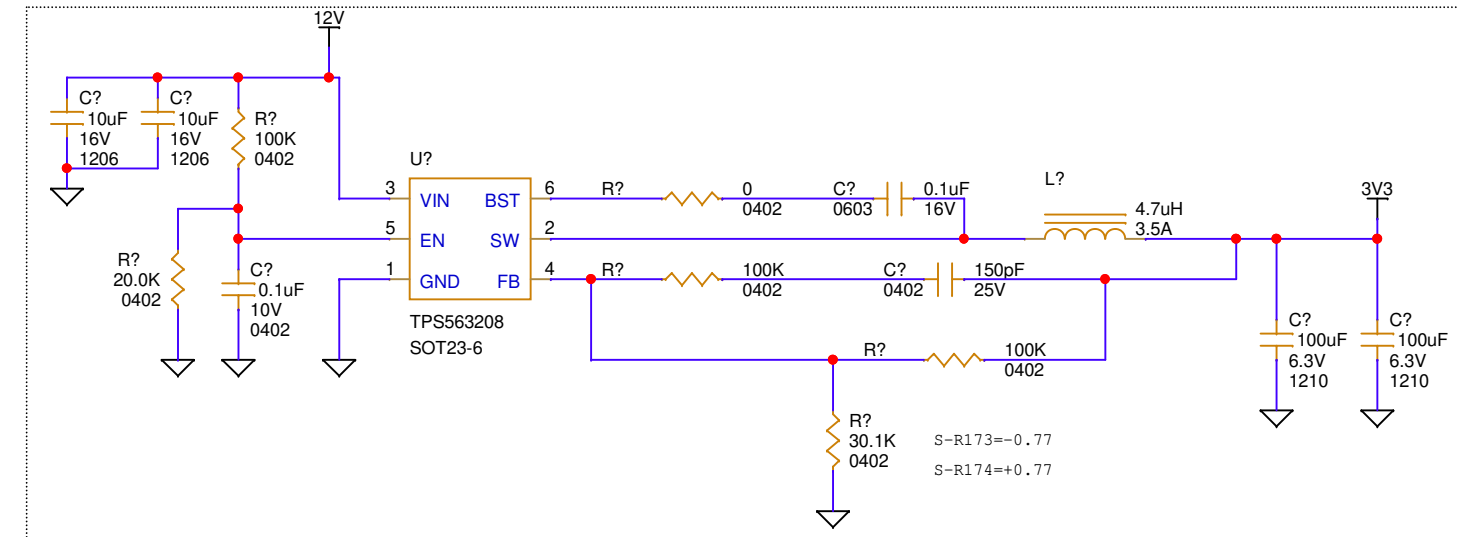
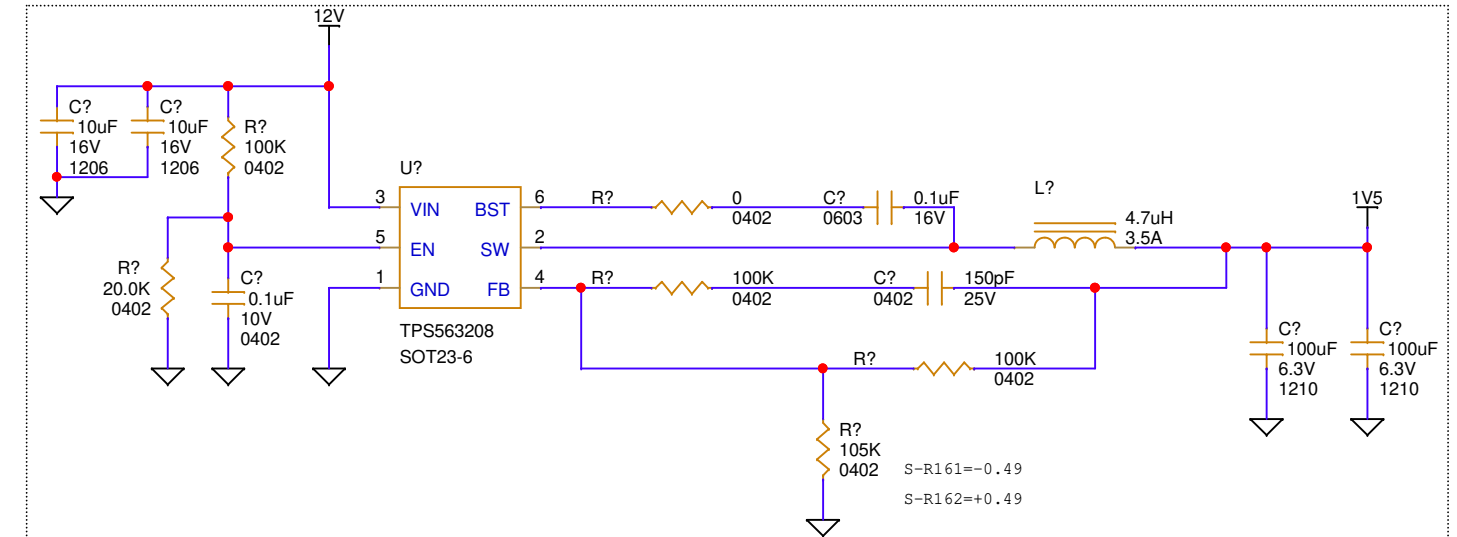
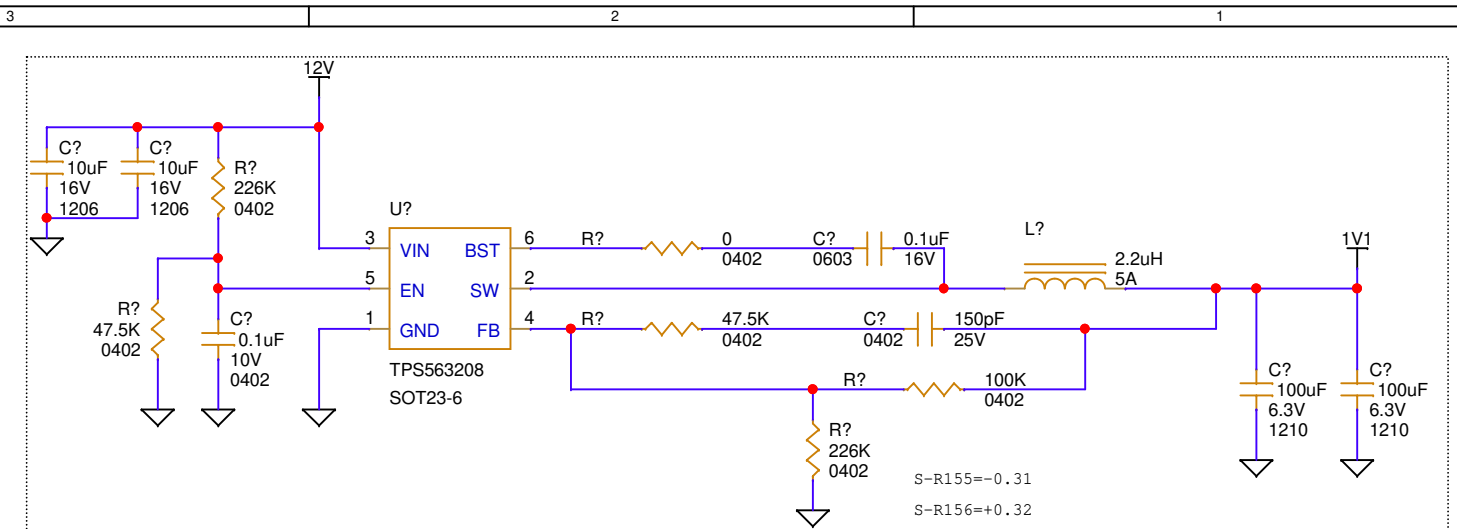

Title <Title>		
Size B	Document Number <Doc>	Rev <Rev Co>
Date:	Monday, December 05, 2022	Sheet 9 of 1